

CHAPTER 6: HEAT TRANSPORT CONTROL SYSTEMS

MODULE 2: PRESSURE CONTROL BY PRESSURIZER

Introduction

For a system equipped with a pressurizer, control is again divided into two modes.

- The solid mode, which is the wide range control system, is used for warm up and cool down operations. The pressurizer is isolated from the system by MV1 and control is by a split range pressure control system, as previously described, using feed and bleed valves.
- Under normal, at power, operating conditions pressure control is effected by the pressurizer.

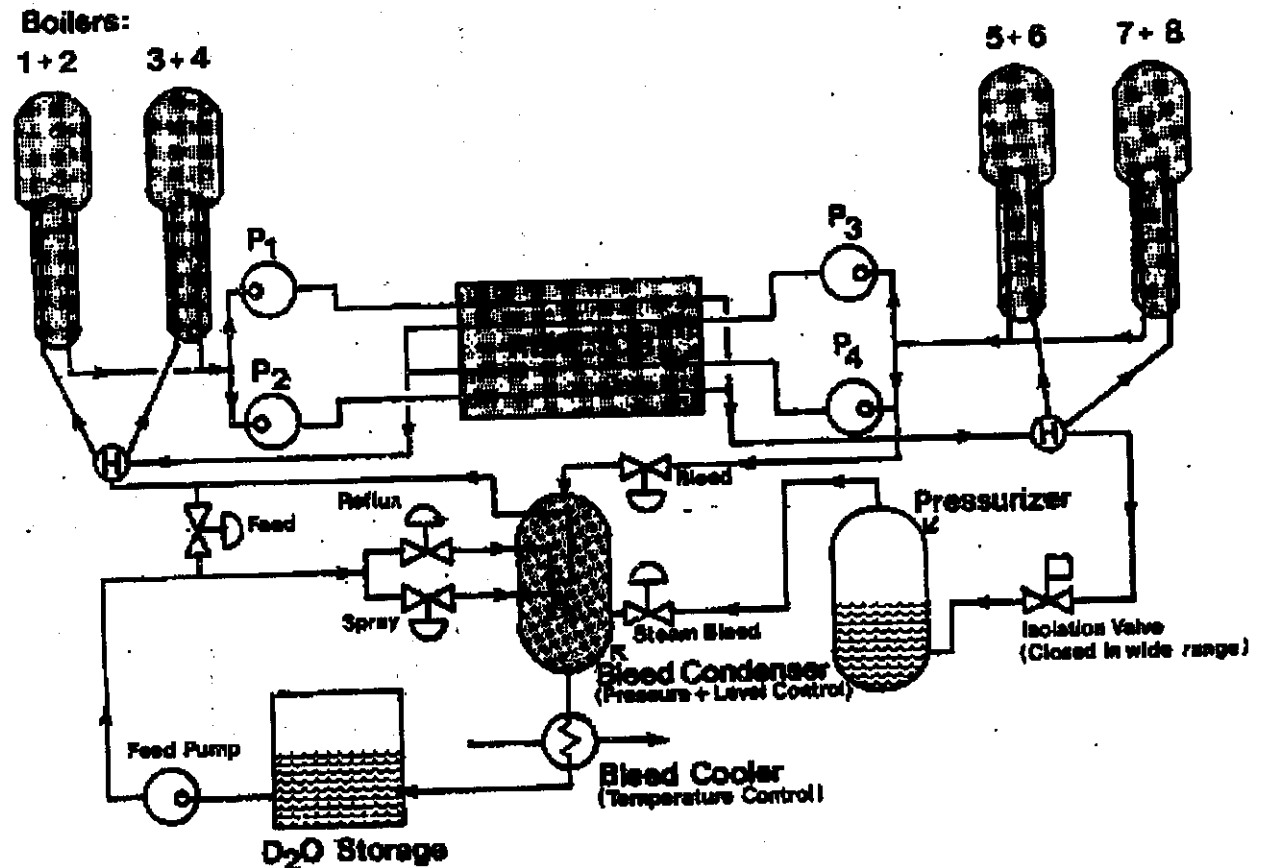

Figure 1: Simplified CANDU Heat Transport System with Pressurizer.

Wide Range (Solid Mode) Control

When in the solid mode, saturation conditions are established in the pressurizer (9 MPa(g), 304°C). This saturation pressure is established by a combination of electric heaters and steam bleed valves. If the pressure is too high it will cause the steam bleed valves to open and high pressure will also switch off all of the heating elements. The opposite occurs if the pressure is too low, i.e., steam valves close and heaters are progressively switched on.

It is also necessary to prevent heater operation if an insufficient level of D₂O is present in the pressurizer. If the level is too low all heaters will switch off.

Narrow Range (Normal Mode) Control

Pressure control under these conditions is performed exclusively by the pressurizer. The isolation valve MV1 is opened and pressure is controlled by manipulation of the heaters and the steam bleed valves. The feed and bleed system is used only for purification and inventory control purposes.

During power increases the heat transport fluid expands and excess (swell) flows into the pressurizer. It is most important that the pressurizer should never become full of liquid (a condition referred to as "solid"), it must always have a vapour (steam) space. In the case of a large swell the level control will operate the feed and bleed valves to relieve some of the excess thus preventing the loss of the vapour space.

An increase in HTS pressure will require that steam pressure be relieved by opening the steam bleed valves. Conversely a decrease in pressure will require the heaters to be switched on to raise the pressure in the pressurizer and therefore the pressure in the HTS.

Pressurizer Instrumentation and Control Logic

Heat transport system pressure is sensed by six pressure transmitters PT1-6 arranged three to each reactor outlet header.

Paired transmitters, one from each header, have their outputs routed via a high signal selector (HI) eliminating the effect of a transmitter which fails to zero output (the usual failure mode).

Each of the three high signals is then routed to a pressure controller (PIC1 - 3), the outputs of which are fed to a median select circuit which provides the signal for the steam bleed valves.

Low pressure is sensed by current sensors (CA1-3) which will switch on the heaters to raise pressure. This "heater on" signal is dependent on there being sufficient D₂O in the pressurizer. This conditioning is achieved by the triplicated level transmitters (LT1 - 3) and the two out of three (2/3) module, i.e., low level - heaters switched off.

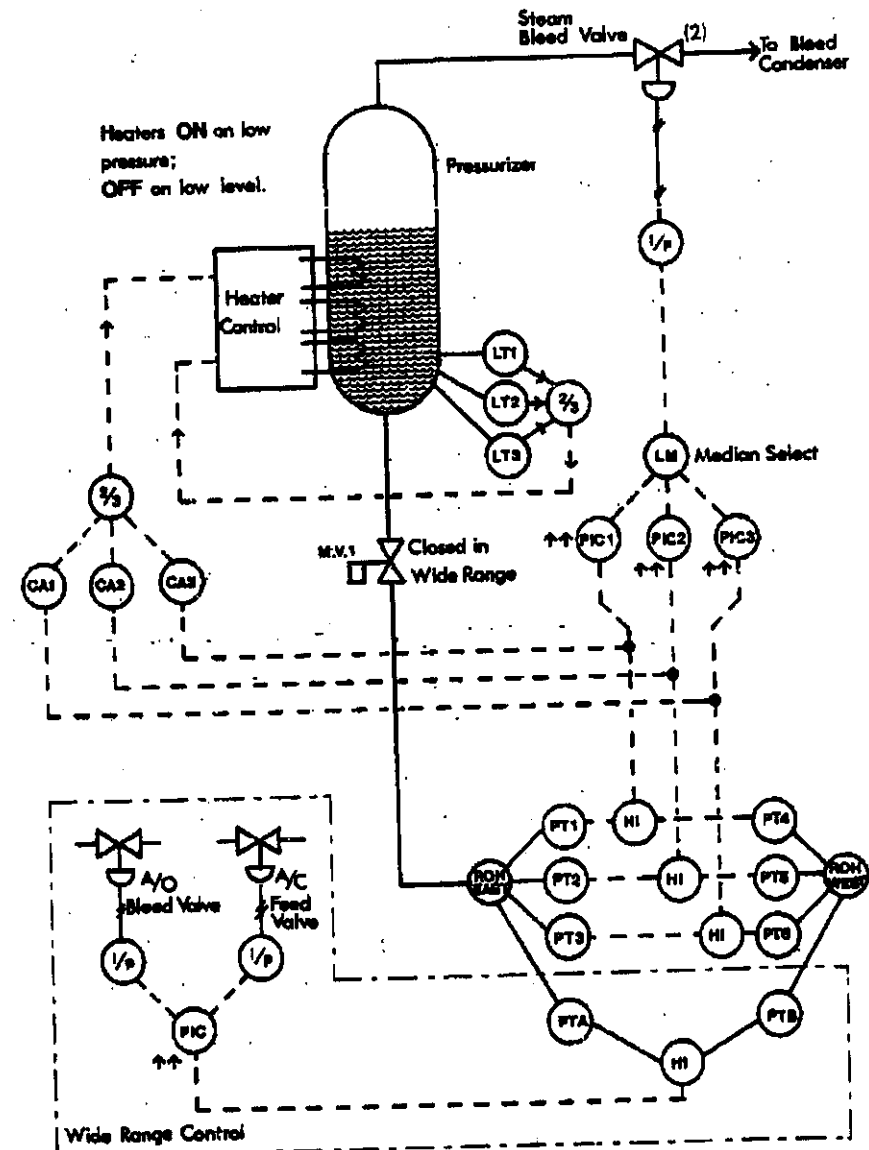

Figure 2: Pressurizer Instrumentation and Control Logic.

Pressurizer level Control

The level in the pressurizer is controlled by the feed and bleed valves to rise as power level is increased. This is done for two reasons:

- (a) to minimize the use of the feed and bleed system and thus ensure the bleed condenser and bleed cooler has a reasonably constant load.**
- (b) to provide an immediate inventory make-up to the HTS system in the event of a reactor trip when D₂O shrinkage, due to the loss of heat source, is at a maximum.**

The pressurizer is fitted with pressure release valves. In the event of the pressurizer pressure rising while isolated above its normal control limits, these valves discharge to the bleed condenser, ensuring that there is no loss of fluid from the system.