

## **CHAPTER 1: INSTRUMENTATION EQUIPMENT**

### **MODULE 4: Level Instrumentation**

#### **MODULE OBJECTIVES:**

At the end of this module, you will be able to:

1. Sketch and explain the principle of an open tank level measurement installation using a level transmitter.
2. Sketch and explain the principle of a closed tank level measurement installation using a level transmitter and dry leg.
3. Explain the purpose of a three-valve manifold in closed tank level measurement installations.
4. State the procedure required for valving a level transmitter:
  - a) into service, and
  - b) out of servicewhen a three valve manifold is used.
5. Briefly explain the principle of operation of a closed tank, wet leg, level measurement installation.
6. Briefly explain the need for
  - a) zero suppression, and
  - b) zero elevationin level measurement installations by reference to an example process application for each case.
7. Briefly explain the principle of operation of a bubbler level measurement system.
8. List two advantages of a bubbler system.

## Inferential Level Measurement

Inferential level measurement techniques obtain a level indication indirectly by monitoring the pressure exerted by the column of liquid.

$$P = S \cdot H$$

where

P = Pressure (Pa)

S = Weight density of the liquid ( $N/m^3$ )

H = Height of liquid column (m)

### Open Tank Application

The high pressure side of the level transmitter is connected to the base of the tank while the low pressure side is vented to atmosphere.

$$P_{\text{high}} = P_{\text{atm}} + S \cdot H$$

$$P_{\text{low}} = P_{\text{atm}}$$

Differential pressure  $\Delta P = P_{\text{high}} - P_{\text{low}} = S \cdot H$

The level transmitter can be calibrated to output 4 mA when the tank is at 0% level and 20 mA when the tank is at 100% level.

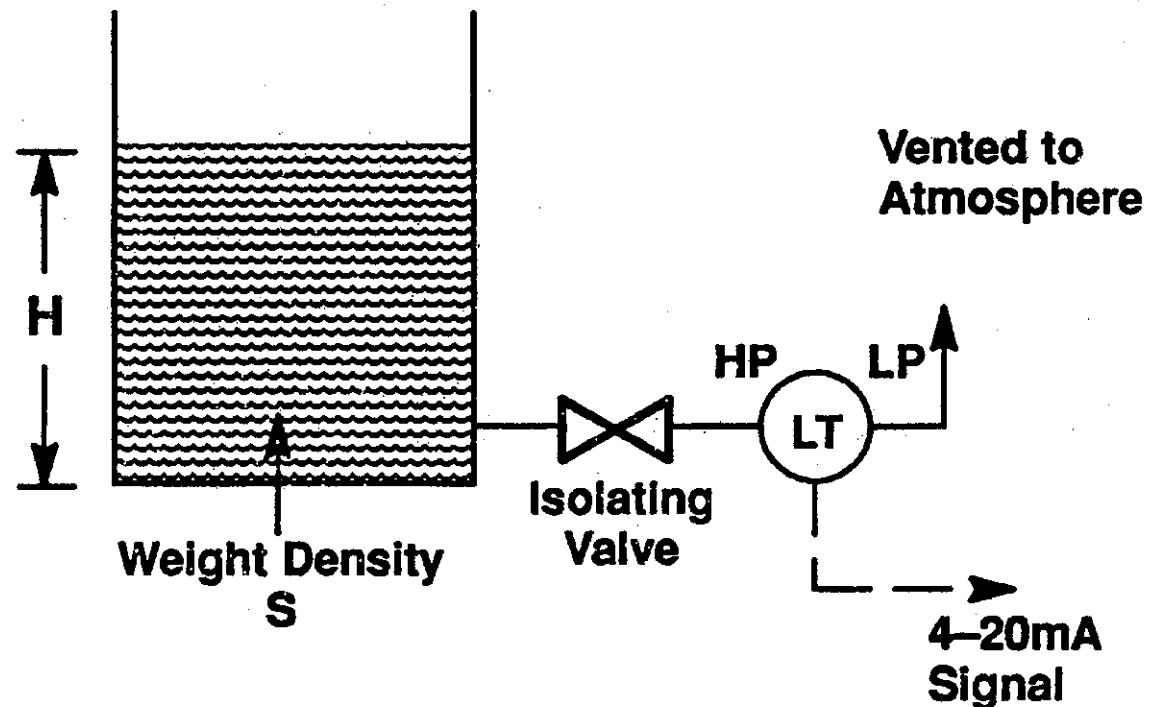

Figure 1: Open Tank Level Measurement Installation.

## Closed Tank Application

- Should the tank be closed, and a gas phase exist on top of the liquid, the gas pressure must be compensated for.
- A change in the gas pressure will cause a change in transmitter output.
- The pressure exerted by the gas phase may be so high that the hydrostatic pressure of the liquid column becomes insignificant
- Compensation can be achieved by applying the gas pressure to both the high and low pressure sides of the level transmitter.

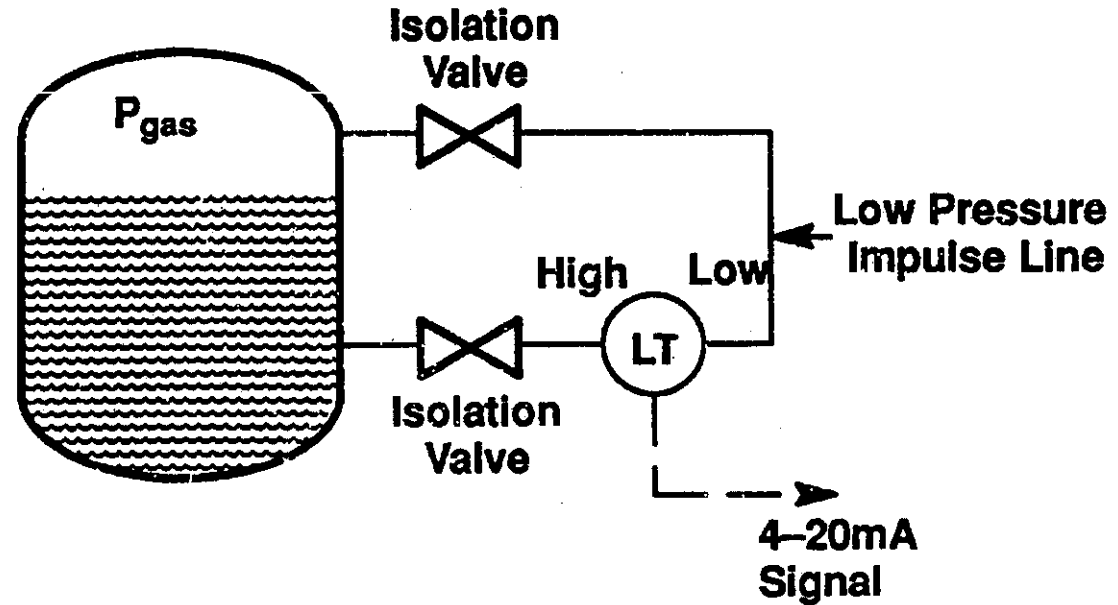

Figure 2: Typical Closed Tank Level Measurement System.

We have:

$$P_{high} = P_{gas} + S \cdot H$$
$$P_{low} = P_{gas}$$
$$\Delta P = P_{high} - P_{low} = S \cdot H$$

- The effect of the gas pressure is canceled and only the pressure due to the hydrostatic head of the liquid is sensed.
- When the low pressure impulse line is connected directly to the gas phase above the liquid level, it is called a dry leg.

## Three Valve Manifold

- Applying excessive pressure to a DP capsule is called overranging, which could damage the capsule.
- A **three valve manifold** is a device that is used to ensure that the capsule will not be over-ranged. It also allows isolation of the transmitter from the process loop. It consists of
  - **two block valves** - high pressure and low pressure block valve
  - and an **equalizing valve**.

- During normal operation, the equalizing valve is closed and the two block valves are open.
- When the transmitter is put into or removed from service, the valves must be operated in such a manner that the high pressure gas phase is never applied to only one side of the DP capsule.

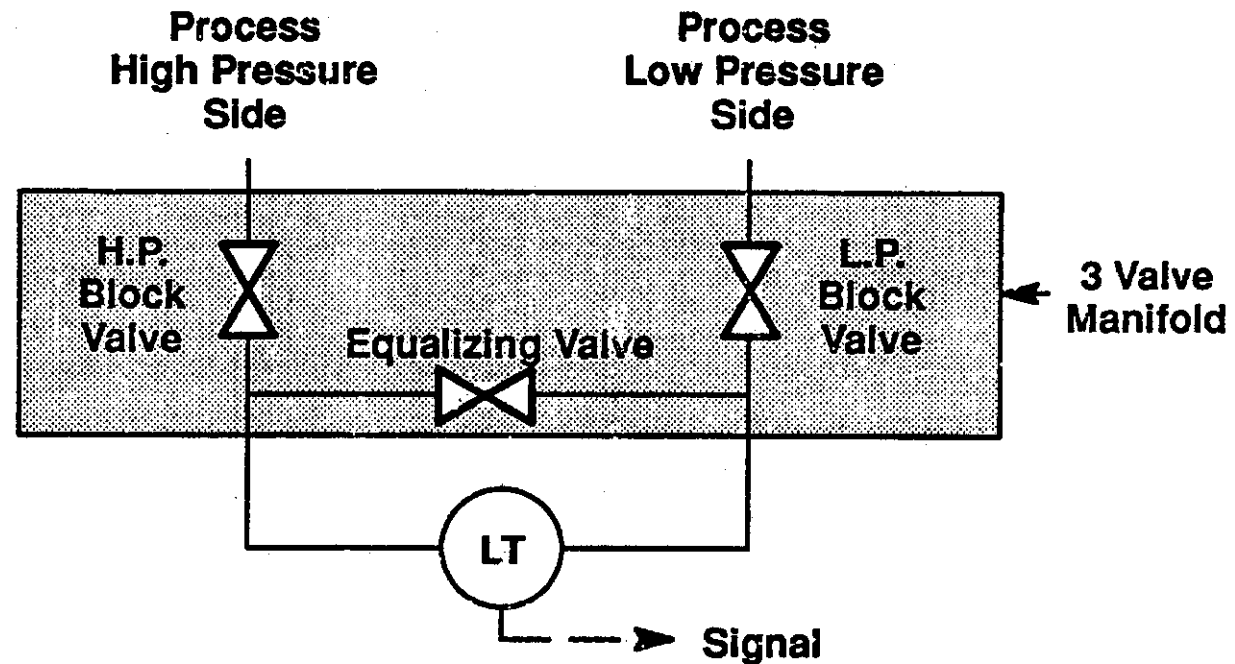

Figure 3: A Three Valve Manifold.

## **Operational Sequences of Three-Valve Manifold Valving Transmitter Into Service**

To valve the DP transmitter into service, the following steps should be followed:

- 1. Check all valves closed.**
- 2. Open the equalizing valve - this ensures that the same pressure will be applied to both sides of the transmitter, i.e. zero differential pressure.**
- 3. Open the High Pressure block valve slowly, check for leakage from both the high pressure and low pressure side of the transmitter.**
- 4. Close the equalizing valve - this locks the pressure on both sides of the transmitter.**
- 5. Open the low pressure block valve to apply process pressure to the low pressure sides of the transmitter and establishes the working differential pressure.**

The transmitter is now in service.

Note it may be necessary to bleed any trapped air from the capsule housing.

Removing Transmitter From Service (reversal of the above steps):

- 1. Close the low pressure block valve.**
- 2. Open the equalizing valve.**
- 3. Close the high pressure block valve.**

## Dry Leg System

- If the gas phase is condensable, such as steam, condensate may form in the low pressure impulse line resulting in a column of liquid which exerts extra pressure on the low pressure side of the transmitter.
- A technique to solve this problem is to add a knock-out pot below the transmitter in the low pressure side.
- Periodic draining of the condensate in the knock-out pot will ensure that the impulse line is free of liquid.
- A disadvantage of the dry leg that restricts its use is the frequent maintenance that is required.

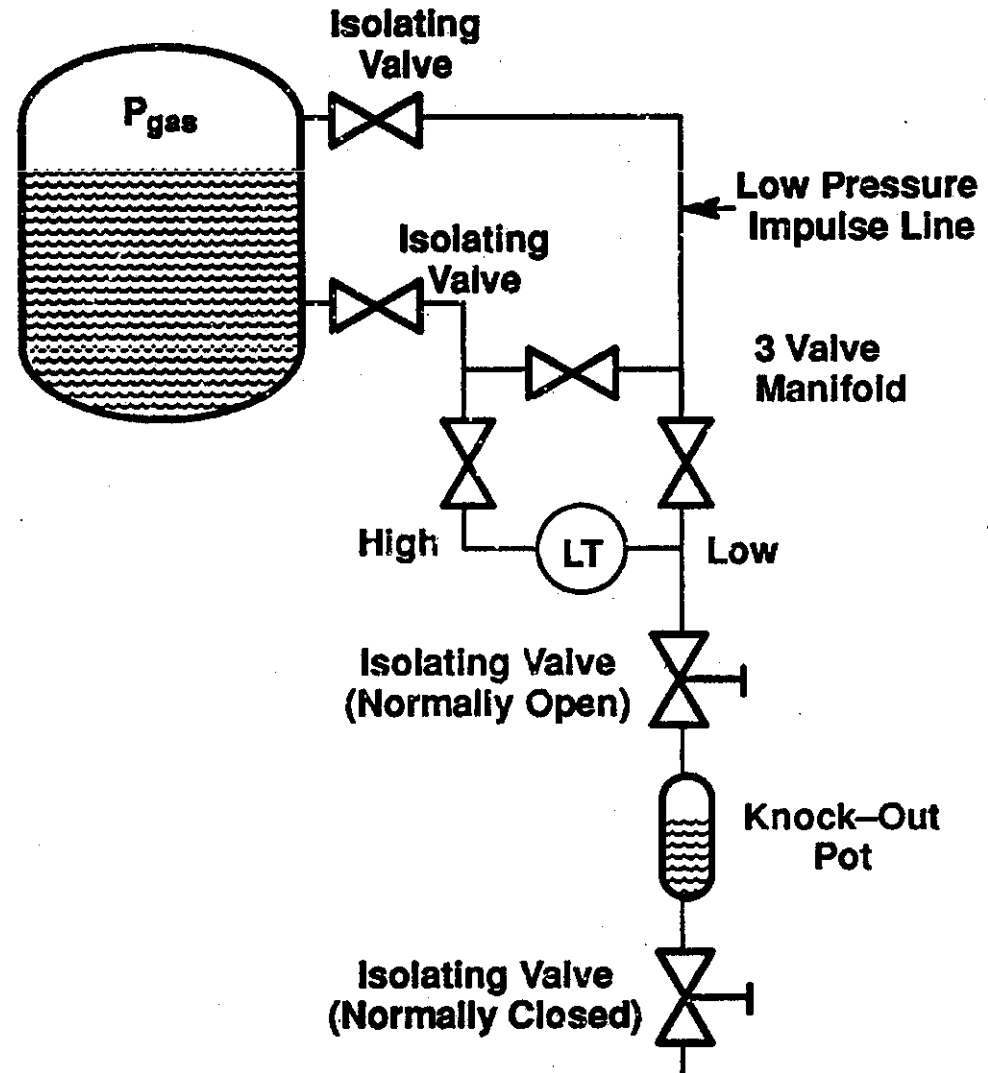

Figure 4: Dry Leg Installation with a Three Valve Manifold.

## Wet Leg System

- In a wet leg system, the low pressure impulse line is completely filled with liquid (usually the same liquid as the process), and hence the name "wet leg".
- A level transmitter, with the associated three valve manifold, is used in an identical manner to the dry leg system.
- The gas phase or vapour will condense in the wet leg and the catch tank.
- The catch tank, with the inclined interconnecting line, maintains a constant hydrostatic pressure on the low pressure side of the level transmitter. This pressure, being a constant, can easily be compensated for by calibration.

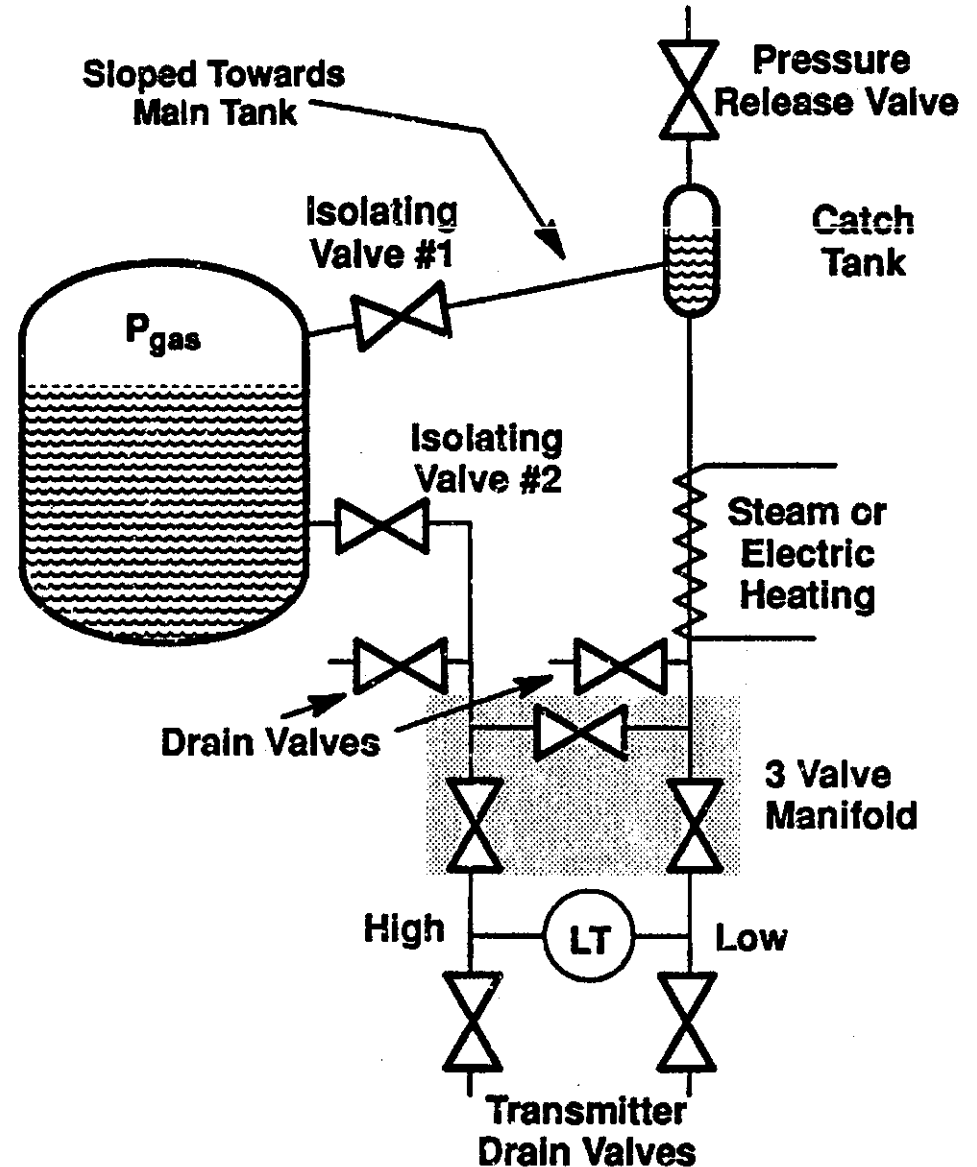

Figure 5: A Wet Leg Installation.

## Zero Suppression

In some cases, the level transmitter has to be mounted X meters below the base of an open tank as shown in Figure 6.

- The liquid in the high pressure impulse line exerts a constant pressure ( $P = S \cdot X$ ) on the high pressure side.
- When the liquid level is at H meters, pressure on the high pressure side of the transmitter will be:

$$P_{\text{high}} = S \cdot H + S \cdot X + P_{\text{atm}}$$

$$P_{\text{low}} = P_{\text{atm}}$$

$$\Delta P = P_{\text{high}} - P_{\text{low}} = S \cdot H + S \cdot X$$

- The transmitter has to be negatively biased by a value of  $-S \cdot X$  so that the output of the transmitter is proportional to the tank level ( $S \cdot H$ ) only.

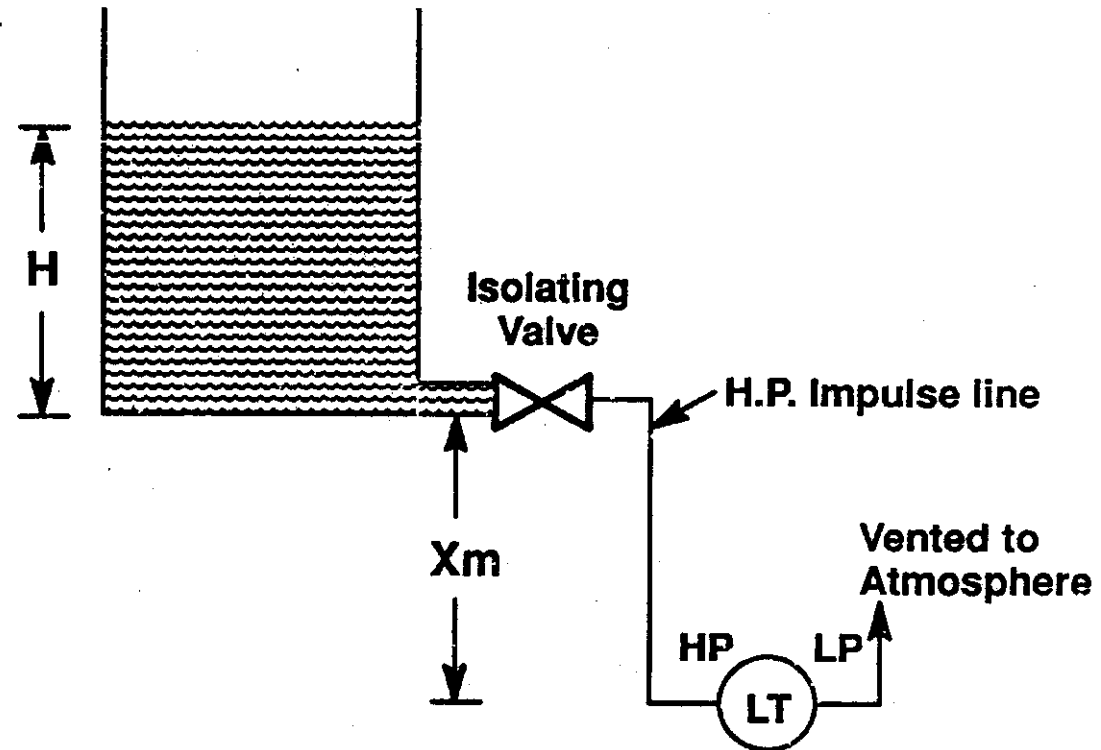

Figure 6: Level Transmitter with Zero Suppression.

- The above procedure is called Zero Suppression and it can be done during calibration of the transmitter.



## Zero Elevation

- Note that (see Figure 7), the height of the wet leg (X) is always equal to or greater than the maximum height of the liquid column (H) inside the tank.
- In a wet leg installation the low pressure side of the level transmitter will always experience a higher pressure than the high pressure side.
- When the liquid level is at H meters, we have:

$$P_{\text{high}} = P_{\text{gas}} + S \cdot H$$

$$P_{\text{low}} = P_{\text{gas}} + S \cdot X$$

$$\Delta P = P_{\text{high}} - P_{\text{low}} = S \cdot H - S \cdot X = -S(X - H)$$

- The differential pressure  $\Delta P$  sensed by the transmitter is always a negative number (i.e. low pressure side is at a higher pressure than high pressure side).
- To properly calibrate the transmitter, a positive bias ( $S \cdot X$ ) is needed to elevate the transmitter output. This positive biasing technique is called zero elevation.

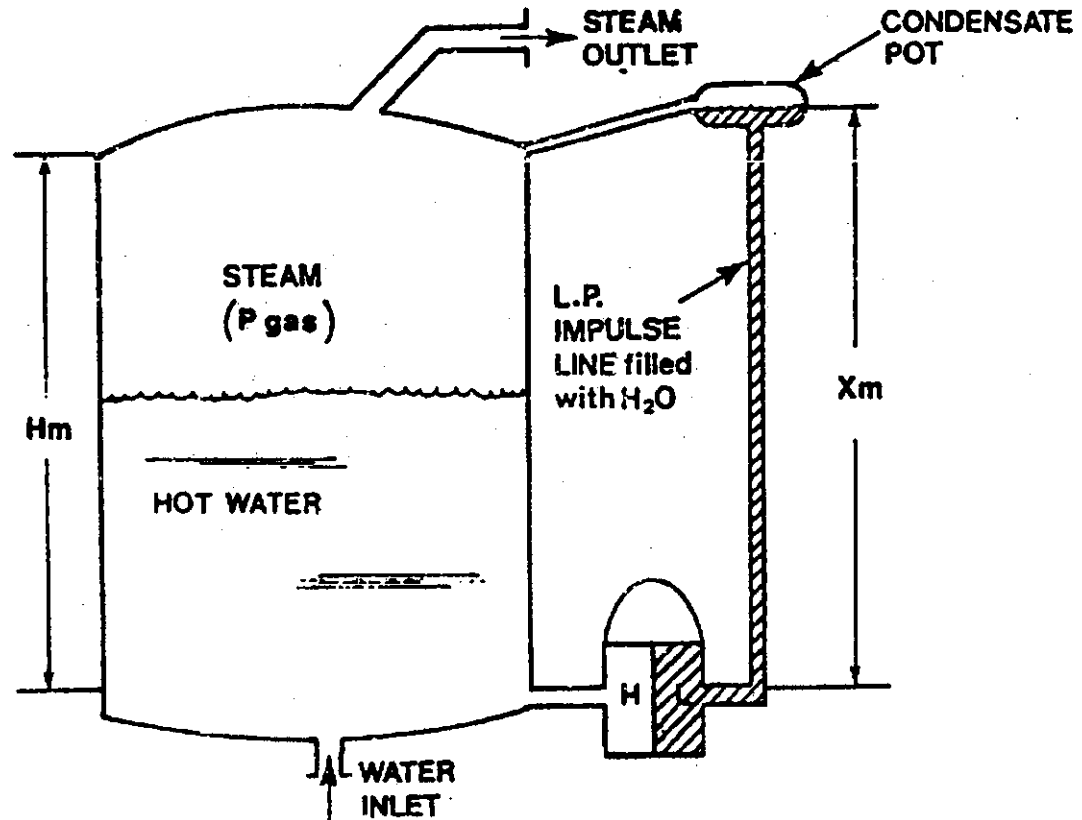

Figure 7: Simplified Wet Leg Installation.

## Bubbler Level Measurement System

This system of level measurement is used when the process liquid cannot be in direct contact with the level transmitter.

The system operates as follows:

- A bubbler tube is immersed to the bottom of the vessel in which the liquid level is to be measured. A gas (called purge gas) is allowed to pass through the bubbler tube.
- When the tank is empty, the gas will escape freely at the end of the tube and therefore the gas pressure inside the bubbler tube (called back pressure) will be at atmospheric pressure.
- As the liquid level inside the tank increases, pressure exerted by the liquid at base of the tank and at the opening of the bubbler tube increases. The gas pressure in the bubbler tube will continue to increase until it just balances the hydrostatic pressure ( $P = S \cdot H$ ) of the liquid. At this point the back pressure in the bubbler tube is exactly the same as the hydrostatic pressure of the liquid and it will remain constant until any change in the liquid level occurs.
- Any excess supply pressure will escape as bubbles through the liquid.
- An additional advantage of the bubbler system is that since it measures only the back pressure of the purge gas, the exact location of the level transmitter is not important. The transmitter can be mounted some distance from the process.

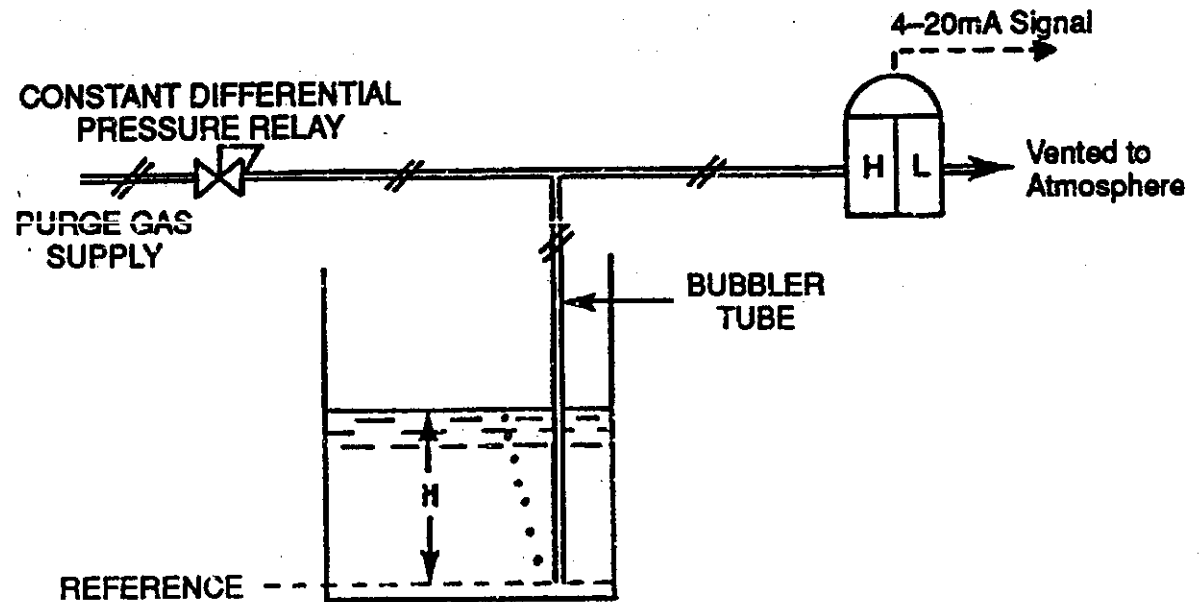

Figure 8: Bubbler Level Measurement System in an Open Tank.