

Electrical Systems - Course 135

FURTHER EXAMPLES OF ELECTRICAL PROTECTIVE RELAYS

1.0 INTRODUCTION

Lesson 235.02-1 examined electrical protective relays used for motor protection and lesson 235.02-2 covered the basics of protective relays and schemes used to protect busbars, transformers, generators and power lines. This lesson examines, in greater detail, the principles of relays used to protect generators, transformers etc. The next two lessons will examine how these relays are connected to form composite ac and dc protective schemes for transformers, generators and other items of electrical equipment in a generating station or heavy water plant.

2.0 DIFFERENTIAL RELAYS2.1 Principle of Operation

Figure 1(a) shows the principle of differential protection applied to a healthy busbar circuit. Current transformers (CT's) of equal ratio are installed on the external side of the breakers which protect a section of busbar B_1 . A current operated relay is connected between two wires interconnecting the CT's. During healthy conditions, equal currents will flow in and out of the circuit and because the CT's have equal ratios, each CT will give an equal output. The CT outputs I_{S1} and I_{S2} will circulate around the interconnecting circuit. Note, that the currents in the relay, flow in opposite directions and therefore cancel.

Figure 1(a) shows the instantaneous directions of current flow and Figure 1(b) the dc equivalent of the ac secondary circuit. This circuit illustrates the current behaviour in the secondary circuit.

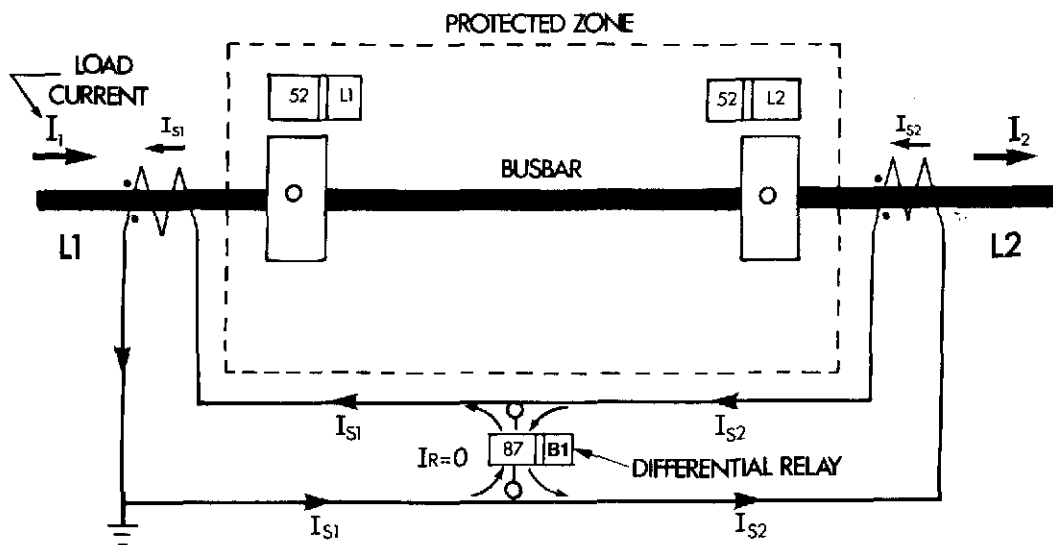

Figure 1(a): Healthy busbar - currents in relay balance; relay 87-B1 does not operate.

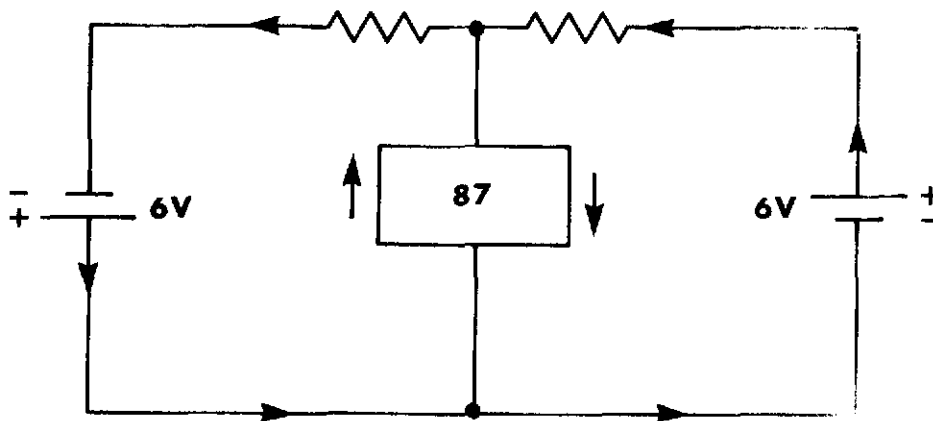

Figure 1(b): DC equivalent of the ac secondary circuit.

In Figure 2(a) the primary currents I_1 and I_2 are not equal and consequently the secondary currents are not equal. There will be a resultant current in the relay causing it to operate and trip the two breakers 52-L1 and 52-L2, deenergizing the busbar. Figure 2(b) shows the dc equivalent of the ac secondary circuit.

Because the differential relay (87-B1) will not operate with load current or "through faults" ie, faults outside the protected zone, it can be set to operate at a low value of current thereby giving rapid operation when a fault occurs. A typical setting for relay 87-B1 is 20% of full load current. There is no need to time delay the operation of relay 87-B1 and therefore a fast acting attracted armature type of relay is used.

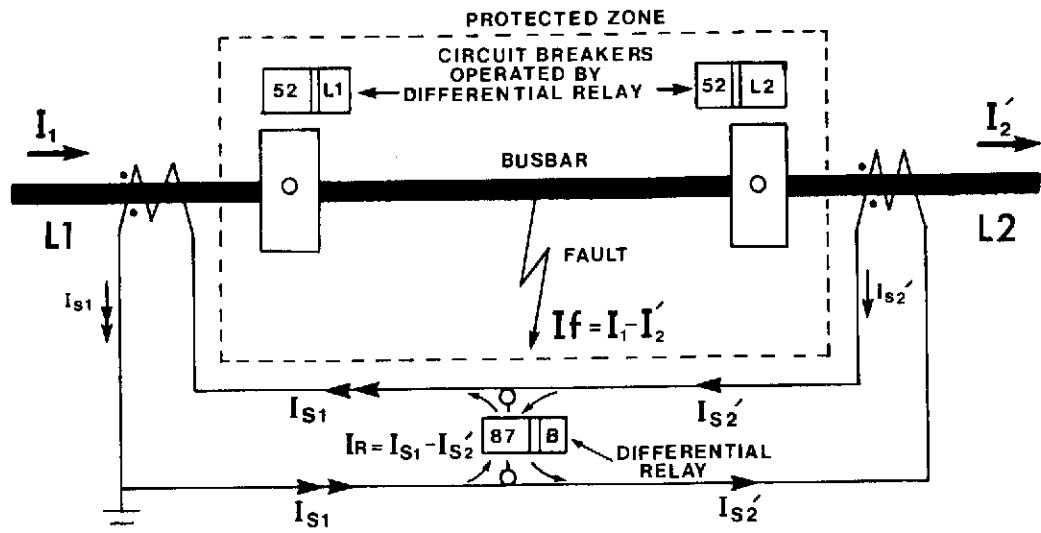

Figure 2(a): Unhealthy or faulted busbar - relay operates with current $I_{s1} - I_{s2}$

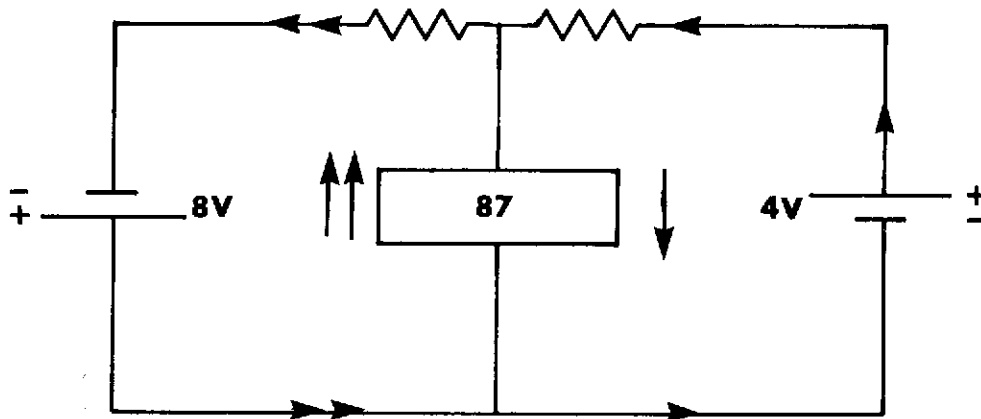

Figure 2(b): DC equivalent of the ac secondary circuit.

Protection of "T" circuits. Figure 3 shows a "T" circuit protected by differential protection. For simplicity, the current is shown to enter via line 1 and leave in equal amounts via lines 2 and 3. Note:

- (a) the protected zone.
- (b) the flow of currents in the CT's and secondary circuits.
- (c) there is no current flowing in the relay.

If a fault now occurs inside the zone, the currents entering and leaving the zone will not balance. Current will flow in the relay which will be connected to trip all the three breakers. This type of protection is normally used where "T" connections are employed on busbars and generator circuits.

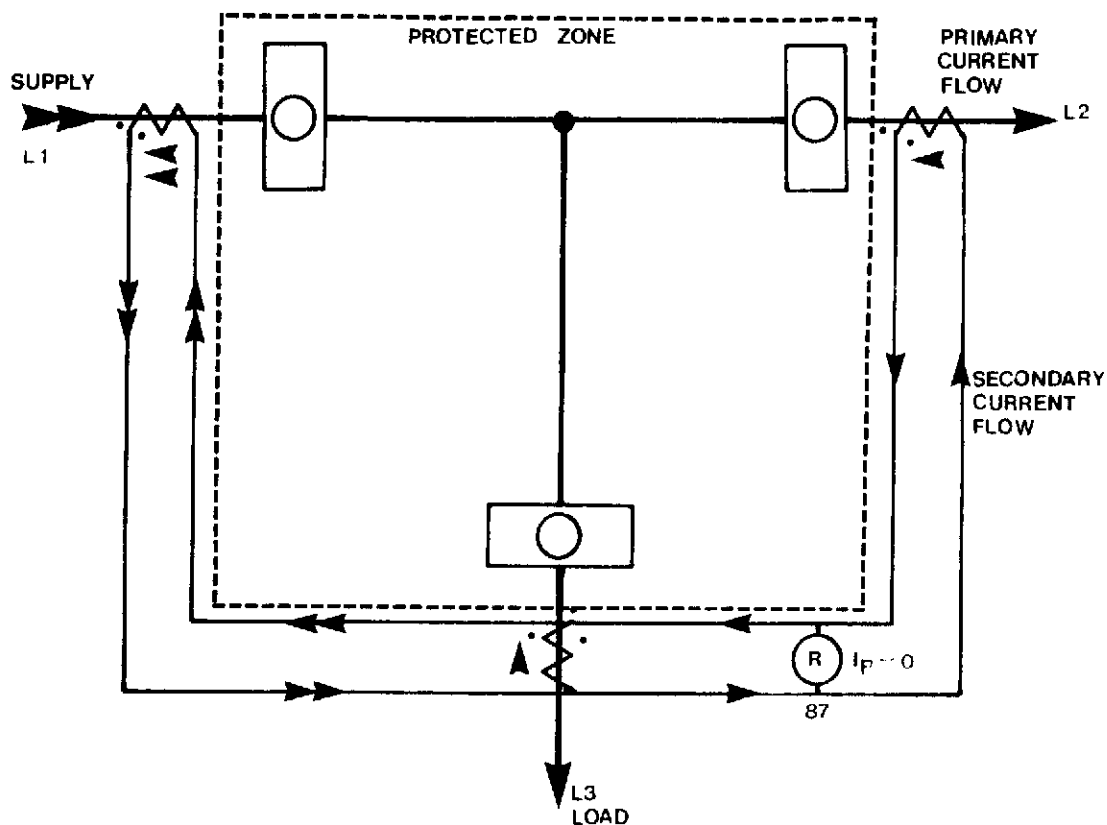

Figure 3: Differential protection applied to a "T" feeder. Note primary and secondary current flow.

2.2 Types of Differential Relay

2.2.1 Simple differential relays. The differential relays shown in Figures 1(a), 2(a) and 3 are simple current operated attracted-armature relays. Although this basic type of relay can be used for protecting generators and transformers, they are rarely used because:

- (a) The CT's feeding the relays, when an out-of-zone fault occurs, may not give exactly balanced outputs. Any unbalance in the output from the CT's may cause the relay to malfunction. The example given in Figure 4 shows the situation which can occur when two CT's each of 500/5 ratio, and each having a 1% error, are subjected to a through or out of zone fault current of 10 kA. The relay, set at 20% of 5A or 1A, will have a current of 2A flowing in it and it will mal-operate causing the breakers to trip incorrectly for the out of zone fault.

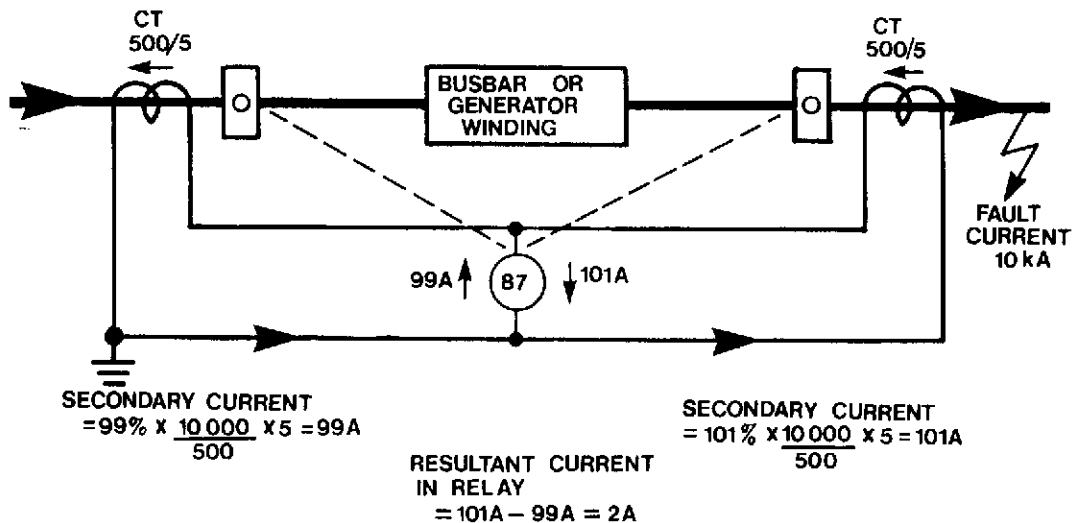

Figure 4: Current transformer errors causing differential relay to mal-operate on an out of zone fault.

(b) In the primary circuit, there may be transformers with tap changers. Tap changers cause the transformer to produce a different voltage and current ratio. Unless the CT's also have taps, (which is very rarely the case), when the transformer is on a tap other than the one giving the nominal ratio there will be an unbalance in the CT output currents.

2.2.2 Percentage Differential Relays. To overcome these problems detailed in 2.2.1 (a) and (b), relays are made with restraint coils as well as operating coils. These restraint coils prevent tripping during through a "out-of-zone" fault conditions, but should an "in-zone" fault occur, tripping will take place.

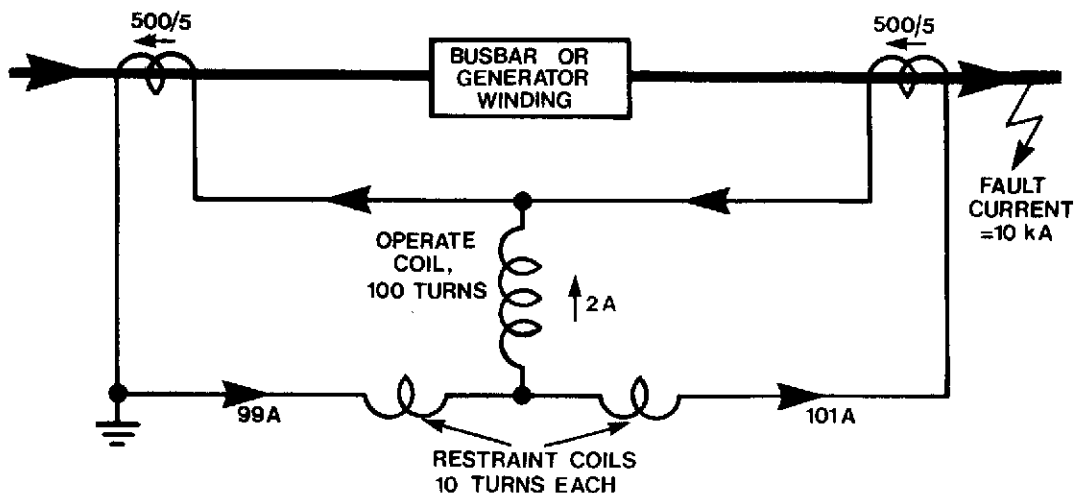

Figure 5(a): Differential relay with restraint coils. Relay does not mal-function when an out of zone fault occurs.

Figure 5(a) shows how the restraint and operating coils are connected. A typical relay is considered, which has 100 turns on its operate coil and 10 turns on each of its restraint coils. Under the same fault conditions as shown in Figure 4, the restraint coils produce $(99 \times 10) + (101 \times 10) = 2000$ ampere-turns. The operate coil produces $2 \times 100 = 200$ ampere-turns. Clearly, the restraint coils produce a greater magnetic force and the relay does not operate. For the relay to operate, the ampere-turns of the operating coil must exceed the ampere-turns of the restraining coil.

Figure 5(b) shows how a balanced beam type of differential relay is used. Under healthy or out of zone fault conditions, the restraint coils have a greater pull and prevent tripping. When an inzone fault occurs, the operate coil has a greater pull and the relay operates tripping the appropriate breakers. The breakers are not shown in Figure 5(b).

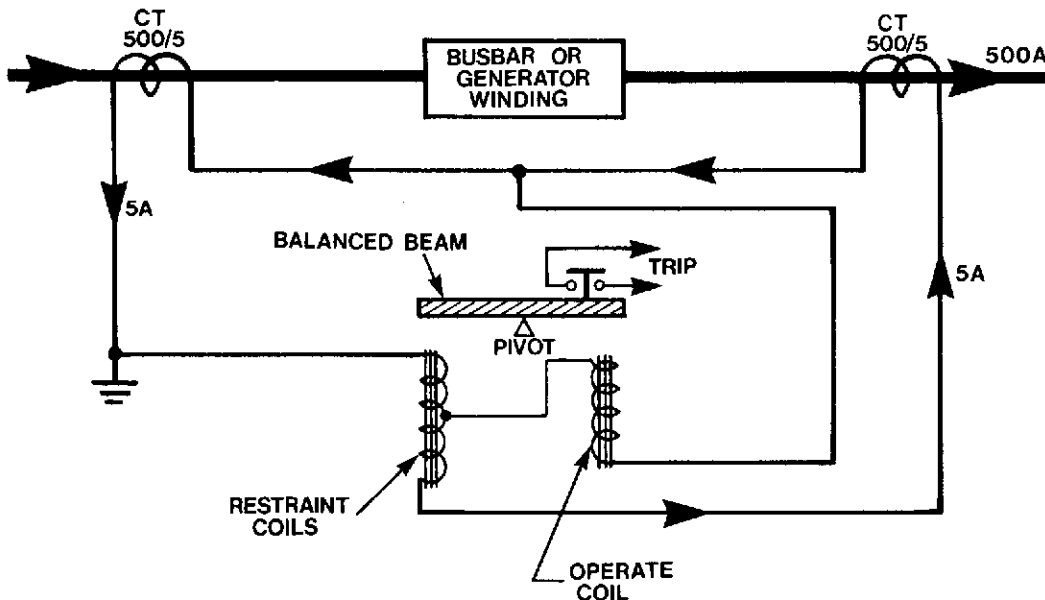

Figure 5(b): Balanced beam type differential relay.

Most manufacturers provide tapplings on the restraint coils. This enables the amount or percentage of the restraint to be altered to allow for:

- (a) CT ratio errors.
- (b) the unbalance in CT outputs produced by tap changers on transformers. See section 2.2.1(b).

To overcome these problems, sufficient (but not too much) restraint has to be provided and this is done by selecting the correct tap. Figure 6 shows, for various percentage tap settings of the restraint coils, curves of through or out of zone fault current versus levels of current to operate the relay.

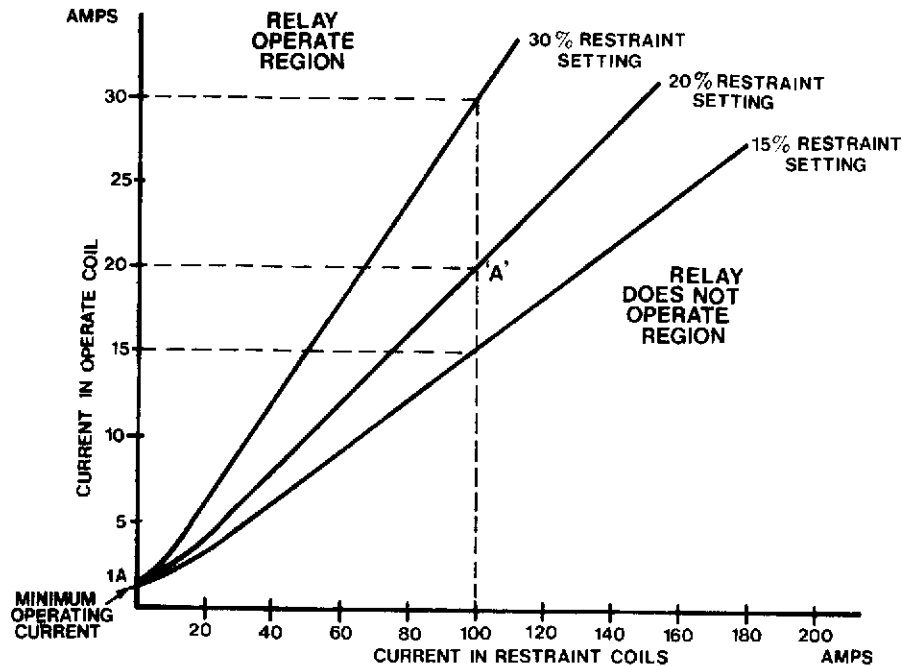

Figure 6: Typical operating characteristics of a percentage differential relay.

Taking the example shown in Figure 4, if the relay is set at 20%, see Figure 6, and 100 A flows in each of the restraint coils each having 10 turns, $100 \times 10 \times 2 = 2000$ ampere turns of **restraint force** are produced.

Before the relay can operate, a current greater than 20 A must flow through the 100 turn operating coil producing more than $20 \times 100 = 2000$ ampere turns of **operating force**. See point A in Figure 6 on 20% restraint setting, (also called 20% slope).

- 2.2.3 Harmonic Restraint Differential Relays. When transformers are switched onto their supply, there is a surge or inrush of current taken from the supply. Consequently, only the CT's on the supply side give an output which will cause a simple or a percentage differential relay to operate. It is worth noting that the surge only lasts for 10 - 20 cycles.

To overcome this problem, relays are produced which have a time delay which prevents tripping for approximately 0.5 sec. Unfortunately, the longer the tripping is delayed, the greater the damage that can be produced in the transformer. Analysis of the surge or inrush current shows that the current consists of appreciable quantities of second and third harmonics of 60 Hz, ie, 120 and 180 Hz. Filters are therefore provided which ensure that:

- (a) only 60 Hz currents flow through the operate coil.
- (b) the 120 and 180 Hz currents are used to produce additional restraint for the relay.

Figure 7 shows how a balanced beam relay can be used to provide the operate, restraint and harmonic restraint features that are required. During normal operation, the restraint coils prevent relay operation. During a healthy "switch in", when the supply side CT's are only giving an output, restraint is provided by the harmonic restraint coil. At any time,

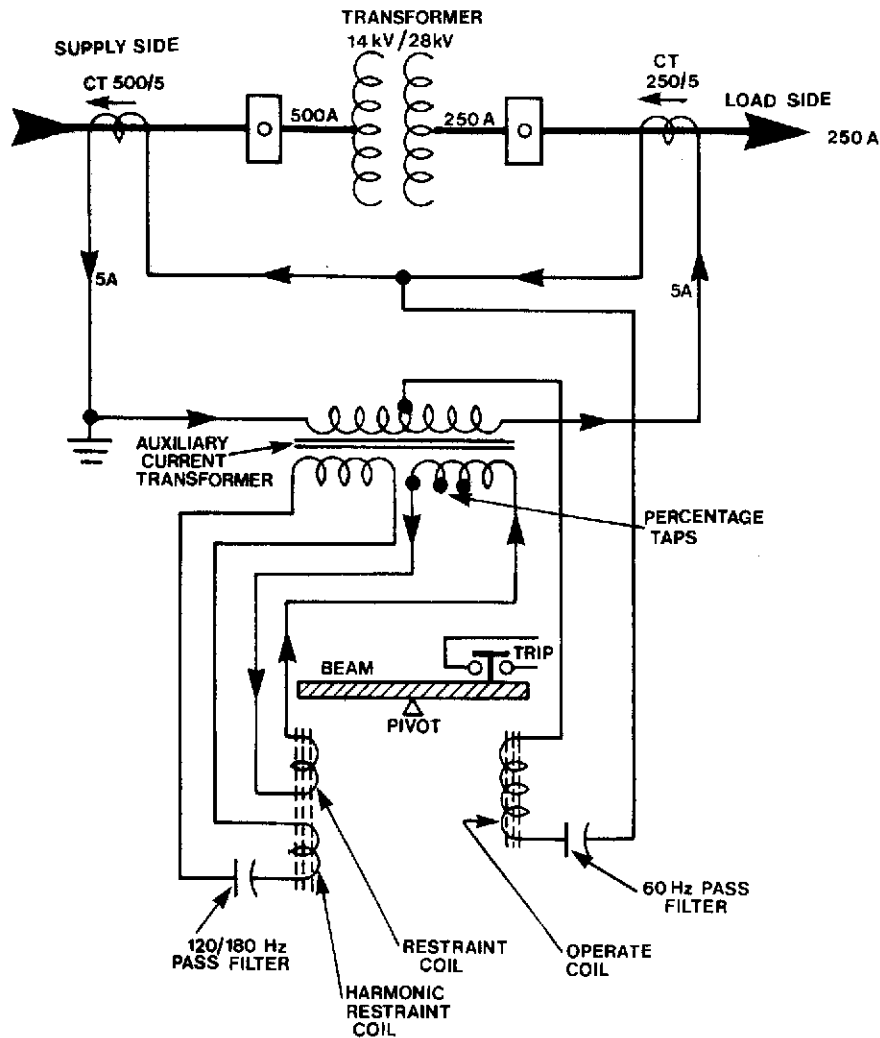

Figure 7: Percentage differential relay with harmonic restraint. Current flow are shown for a healthy condition.

should an in zone fault occur, the operate coil will provide sufficient operating force to tip the beam and send the necessary trip signals. Note, no time delay is required in this relay scheme.

The type of relay shown in Figure 7 shows the essential features for percentage differential protection with harmonic restraint. Some manufacturers, in place of the beam, use a disc, and others an attracted armature relay.

In Figure 7 note that both current transformers have the same secondary current of 5.0 A. This ensures that under healthy conditions no current will flow in the differential relay. This subject is covered in more detail in the next lesson.

3.0 OTHER TYPES OF TRANSFORMER PROTECTIVE DEVICE

3.1 Gas and Oil Relays

While the differential relay is the main means of protection for most transformers in the large sizes and at higher voltages, other measures may be used either alone or in addition to the differential relay. One such scheme which is particularly applicable to the oil filled transformer is the gas relay illustrated in Figure 8.

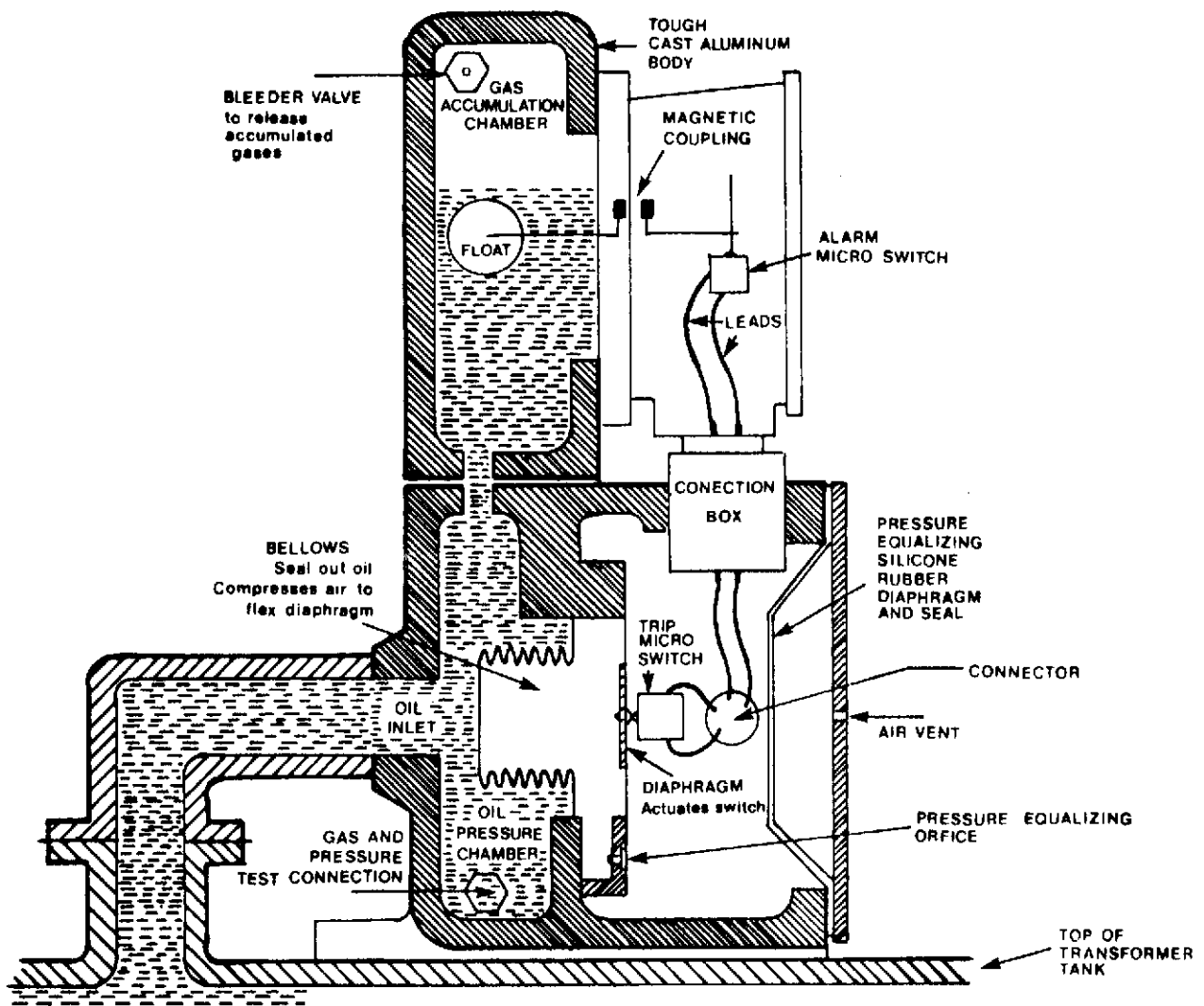

Figure 8: Sectional view of gas and oil relay.

This relay consists of 2 separate elements,

- (a) An upper element which detects the slow accumulation of gas produced by a fault developing in the transformer. For example, a loose connection will produce arcing in the oil. The oil will break down producing quantities of methane, hydrogen, acetylene and other gases. The relay will collect these gases and when the predetermined level has been reached, the float will fall and initiate an alarm. The big advantage of this type of relay is that it detects a fault **inside** the transformer **before** large fault currents flow causing severe damage.
- (b) A lower element operates when a more violent type of fault occurs in the transformer tank. This type of fault produces a pressure surge in the oil which compresses the bellows in the relay. The pressure in the space between the bellows and the diaphragm also rises. This makes the diaphragm flex and push the microswitch which initiates a trip of the transformer.

A gas and oil relay must be mounted at the top of a transformer tank. This will ensure that it will collect all the gases that are produced.

4.0 THERMAL SENSING AND MEASURING DEVICES

4.1 Direct Measurement

In many instances, it is possible to measure the temperature of electrical equipment directly. An example of this, is the method used for measuring the temperature of the core laminations in a generator or motor. A direct measurement is possible because the core is grounded. Another example is where the temperature of water cooled windings in a large turbo-generator are measured by measuring the temperature of the cooling water leaving the windings.

4.2 Indirect Measurement

Measuring the temperature of live conductors is much more difficult and involves the use of insulated sensors or **thermal image** devices.

Insulated sensors are occasionally used to measure the winding temperature of small domestic motors. Because of possible safety implications, they are not used for winding temperature measurement of 3 phase motors in generating stations.

An indication - but not an accurate measurement of the winding temperature in a motor can be achieved by measuring the cooling air temperature. A factor is then added on to allow for the temperature difference between the conductor and the cooling air.

Temperature measurement on motors using thermal relays producing thermal images is explained in lesson see 235.02-1. This method is satisfactory for use in motors but with oil filled transformers, a more accurate method is used.

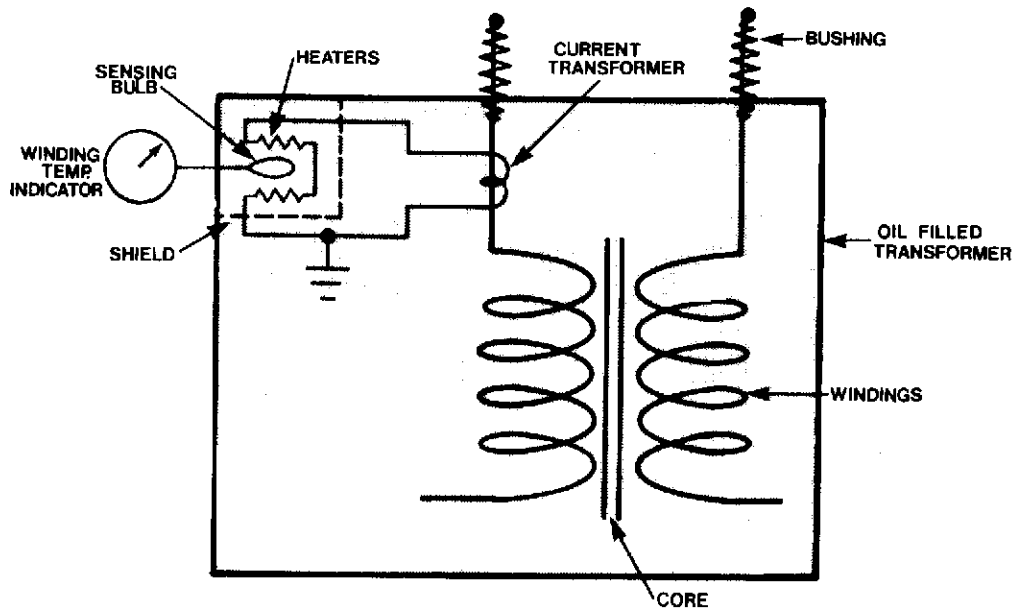

Figure 9: Principle of transformer winding temperature measuring device.

Figure 9 shows the principle of transformer winding temperature measuring device. Under load, the windings and core in a transformer will produce heat which is transferred to the oil. Due to convection, the hottest part of the oil is at the top of the tank. A temperature sensing device situated at the top of the transformer would record the top oil temperature but not the winding temperature. Obviously, the windings will operate at a temperature greater than the top oil temperature. To make the temperature indicator sense a temperature which is the same as the winding temperature, a small heater surrounds the sensing bulb which is placed in the hot oil at the top of the tank. This heater is connected to a current transformer which supplies the heater with a fraction of the main winding current. It would now be appreciated that:

- (a) The winding I^2R and iron losses will heat the oil and due to convection, the hottest oil will be at the top of the tank. Because the winding is a source of heat, the hottest part of the winding - usually called the **winding hot spot** will be hotter than the top oil. The winding hot spot temperature will therefore be the top oil temperature **plus** an increase due to the I^2R produced in the winding.
- (b) The winding temperature indicator will indicate the hot spot temperature, ie, the top oil temperature **plus** an increase due to I^2R produced by the heater.
- (c) The winding temperature indicator, after being correctly set up by the manufacturer, will give a true **thermal image** of winding hot spot temperature under all operating conditions.

4.3 Temperature Measurement Using Change in Resistance

Because of reactance being present, resistance in ac circuits cannot be measured by applying ac voltage and current. However, on dc circuits, temperature is frequently measured by observing the change in resistance of a coil or a winding and converting this change in resistance into a temperature reading. This type of measurement is used to measure the temperature of the dc rotor windings in an ac generator.

Figure 10 shows how the resistance of copper varies linearly with temperature. If the temperature of a winding is reduced, then at some temperature $-T$, the value of resistance will become zero, i.e., material becomes superconducting. Figure 10 illustrates this.

The cold conditions are represented by the solid triangle and the hot conditions are represented by the dotted triangle. As the triangles are similar, then the magnitudes of their sides are in direct ratio.

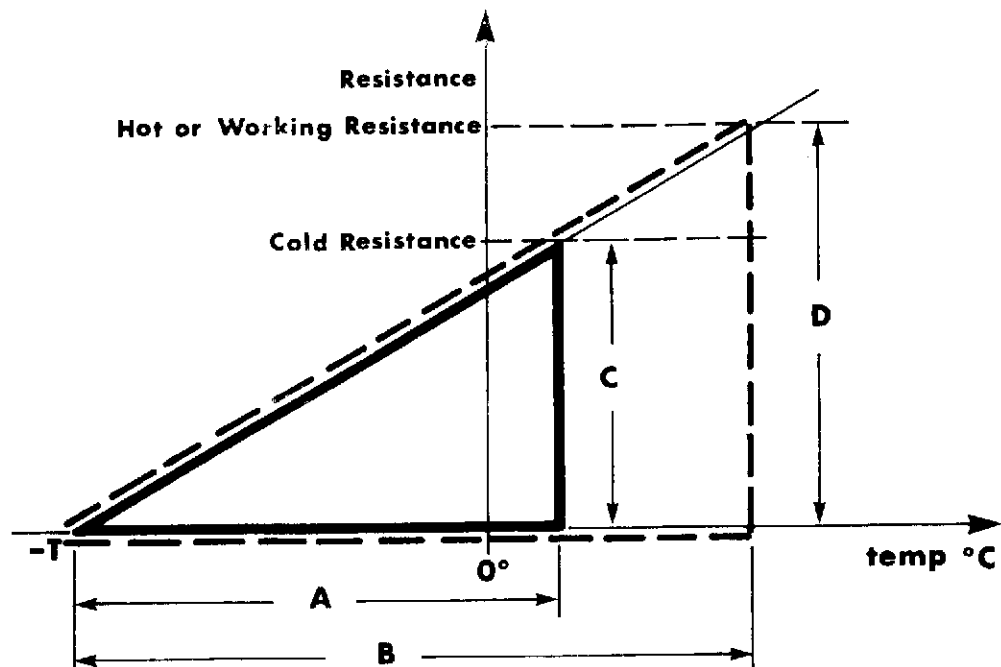

Figure 10: Resistance as a function of temperature.

Therefore, by comparing lengths of the sides of the triangles,

$$\frac{A}{B} = \frac{C}{D}$$

Note:

Length A is $-T$ plus the cold temperature
 Length B is $-T$ plus the hot or working temperature
 Length C is the cold resistance
 Length D is the hot resistance

The best way of illustrating the above is to consider an example.

Example:

A generator rotor takes 4000 A at 400 V at 20°C and 4000 A at 480 Volts when operating at its operating temperature. The rotor is wound using a copper conductor. What is the operating temperature of the conductor?

$$\text{Cold resistance} = \frac{V}{I} = \frac{400}{4000} = 0.1$$

$$\text{Hot resistance} = \frac{480}{4000} = .12$$

Substituting the above in the equation:

$$\frac{A}{B} = \frac{C}{D}$$

gives $\frac{20 + 234.5}{B} = \frac{.1}{.12}$ The value of $-T$ of -234.5°C is obtained from Table 1.

$$\text{Length } B = \frac{.12}{.1} \times 254.5 = 305^{\circ}\text{C above } -T^{\circ}\text{C}$$

$$\text{Hot Temp} = 305^{\circ} - 234.5^{\circ} = 70.5^{\circ}\text{C above } 0^{\circ}\text{C}$$

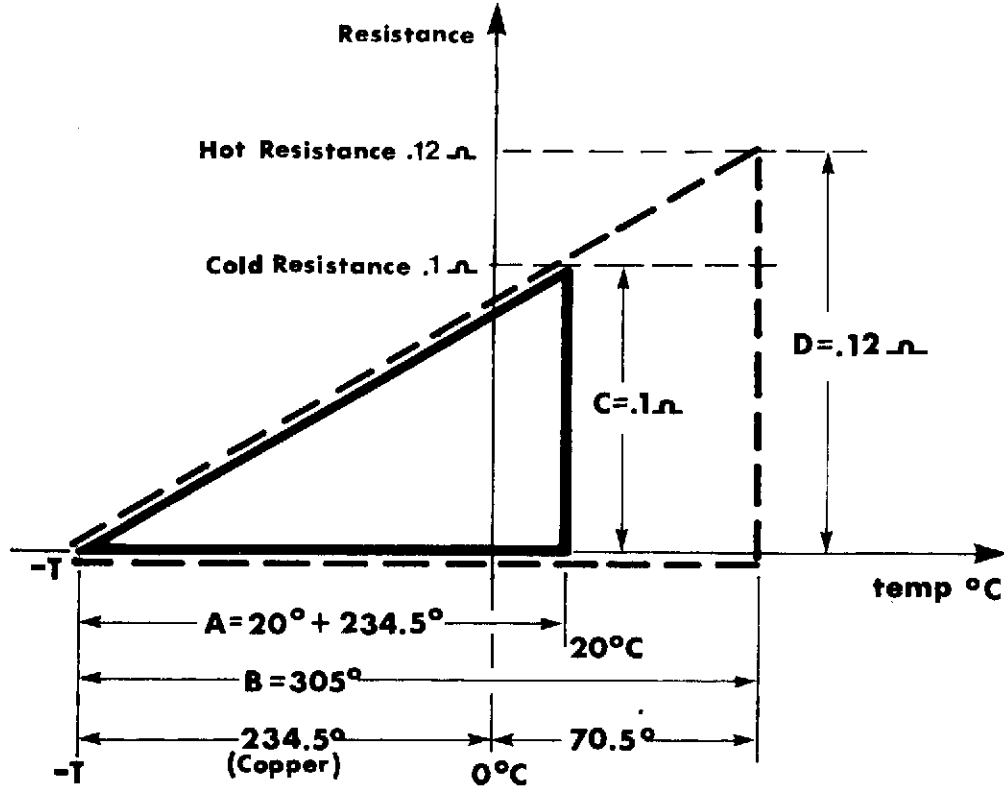

Figure 11: Diagram Illustrating Example.

Table 1: Values of $-T$ for Some Common Electrical Conductor Materials

CONDUCTOR MATERIAL	$-T$ (in $^{\circ}\text{C}$)
Silver	-243
Copper	-234.5
Aluminum	-236
Tungsten	-202
Nickel	-147

Where a spot or a single reading is required, the voltage and current are measured with the winding cold and then a further reading is taken of voltage and current when the winding is hot. A calculation will then give the winding temperature.

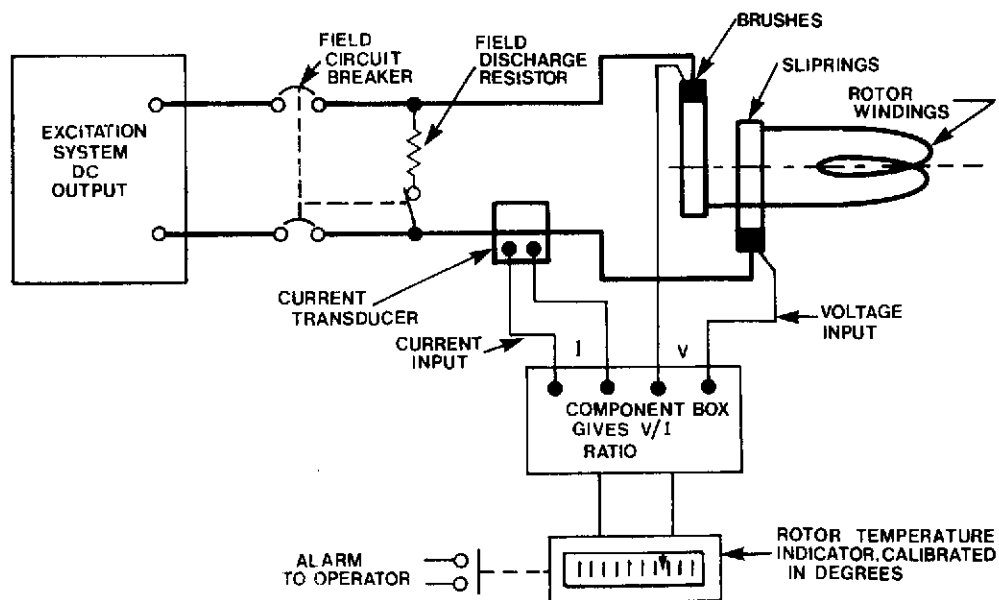

Figure 12: Circuit for rotor temperature indicator.

Where continuous monitoring of temperature is required, for example on the dc rotor of a turbine-generator, an instrument called a **rotor temperature indicator** has been devised. This indicator measures the resistance by comparing the ratio of voltage to current. Figure 12 shows the basic circuitry of a rotor temperature indicator for a turbo-generator. The indicator is supplied with alarm contacts which warn the operator when the rotor temperature limit has been exceeded.

ASSIGNMENT

1. By considering "in zone" and "through" faults, explain, using labelled diagrams, how differential protection is used to protect a busbar.

2. (a) By considering "in zone" and "through" faults, explain, using labelled diagrams, how differential protection is used to protect a busbar with a Teed connection.

(b) Will all the current transformers have the same ratio? Why/why not?

3. Explain, using labelled diagrams, why:

(a) percentage differential relays are required for protecting generators.

(b) percentage differential relays with harmonic restraint are required for protecting transformers.

4. (a) Explain how a transformer can be protected using a gas and oil relay.

(b) State why the gas and oil relay can protect the internal components in a transformer but cannot protect the rest of the circuit.

(c) Given an outline diagram of a gas and oil relay, label the principal components and explain their function.

5. Using a labelled diagram, explain how to accurately measure the temperature of the windings of a loaded transformer.

6. Using a labelled diagram, explain how to accurately measure the temperature of the rotor windings in a turbo generator. The turbo-generator is assumed to be on full load.

J.R.C. Cowling