

CHAPTER 4

HEAT TRANSPORT

CHAPTER OBJECTIVES:

At the end of this chapter, you will be able to describe the following features of the CANDU heat transport systems:

1. The functions of the main or primary heat transport system, the pressure and inventory control system, and the shutdown cooling system;
2. The layout and major components of the main circuit;
3. The major components and operation of the pressure and inventory control system;
4. The equipment and operation of the shutdown cooling system;
5. The main operating characteristics of the heat transport system.

The heat transport system is the first main link in the process of transferring the energy released from fission to electricity. It also has key safety functions in assuring constant cooling of the fuel, as well as forming one of the containment barriers against fission product release. Along with reactor core calculations, the response of the heat transport system under abnormal and accident conditions has been the subject of extensive research and analysis.

This chapter describes the functions, features, equipment and operation of the main (or primary) heat transport system, the pressure and inventory control system, the shutdown cooling system, and auxiliary systems that deal with heat transport purification and heat transport heavy water collection.

The Emergency Core Cooling System that operates to assure cooling of the fuel during a loss of coolant accident will be discussed in Chapter 6.

4.1 MAIN HEAT TRANSPORT SYSTEM

The main (or primary) heat transport system circulates pressurized heavy water coolant through the reactor fuel channels to remove heat produced by fission of natural uranium fuel. The heat is carried by the reactor coolant to the steam generators where it is transferred to light water to produce steam, which subsequently drives the turbine-generator. A schematic flow diagram for the heat transport system and its auxiliary systems is shown in Figure 4.1.

The main functions and features of the heat transport systems are as follows:

- Transports heat produced by the fission of natural uranium fuel in the reactor fuel channels to the steam generators, where the heat is transferred to light water to produce steam.
 - Provides cooling of the reactor fuel at all times during reactor operation and provide for the coolant to remove decay heat when the reactor is shut down.
 - Each heat transport pump has sufficient rotational inertia so that the rate of coolant flow reduction matches the rate of power reduction following the reactor trip if power to the pump motor is lost.
 - A shutdown cooling system is provided to remove reactor decay heat following shutdown. This system permits the draining of the heat transport pumps and the primary side of the steam generators for maintenance.
 - Allows decay heat removal by natural circulation under total loss of pumping power.
 - Limits the effect of postulated loss-of-coolant accidents to within the capability of the safety systems and provide a path for emergency coolant flow to the reactor fuel in the event of such an accident.
- Heat transport system pressure is controlled for all normal modes of operation, and overpressure protection is provided by instrumented relief valves and reactor regulating and/or safety shutdown system action.
- Contains the heat transport system heavy water inventory with minimum leaking or downgrading.
 - Provides containment for fission products that may be released from defected fuel during normal operating conditions.
 - Potential heavy water leak sources (such as at valves and mechanical joints) are kept to a minimum by using welded construction wherever practicable. Where potential leak sources exist, they are connected to closed collection and recovery systems.
- Purification by filtering, ion exchange and degassing is provided to control the chemistry of the reactor coolant.
- Provides process measurements for tripping and shutting down the reactor to ensure that system pressure is within allowable limits.
- Provides process measurements for detection of loss-of-coolant conditions and initiation of emergency core coolant injection, in conjunction with other process signals.
- The heat transport system is seismically qualified to the design basis earthquake. Auxiliary systems which form part of the heat transport system boundary are also seismically qualified. These include the shutdown cooling system, part of the pump seal system and part of the pressure and inventory control system.

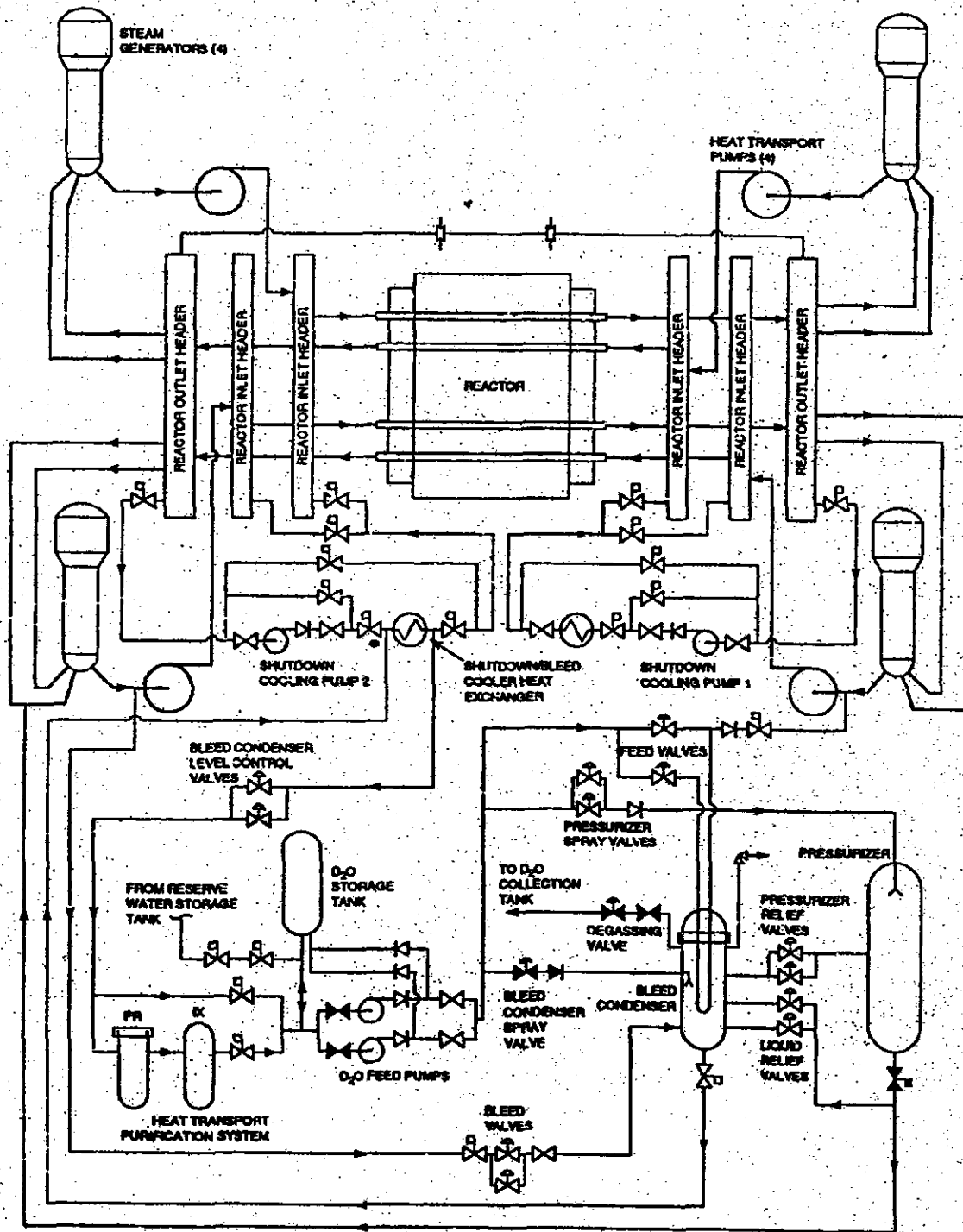

Figure 4.1. Heat Transport Systems Simplified Composite Flow Diagram.

The major components of the heat transport system are the reactor fuel channels, four vertical steam generators, four motor-driven pumps, four reactor inlet headers, two reactor outlet headers and the interconnecting piping.

The reactor coolant outlet of each steam generator is connected to one heat transport pump by a pump suction line. Each pump has one discharge pipe, connected to a reactor inlet header which supplies flow to the fuel channels in one quarter of the reactor fuel channels via individual inlet feeders. Each steam generator has two reactor coolant inlet pipes connected to a reactor outlet header which receives flow from the fuel channels via individual outlet feeders. Adjacent channels are alternatively connected to separate inlet and outlet headers by means of inlet and outlet feeders. The complete circuit forms a figure-of-eight loop, as can be seen from Figure 4.1.

The reactor outlet headers are interconnected by a relatively small pipe with an orifice to assure system thermohydraulic stability.

Four identical steam generators using inverted vertical U-tube bundles in a shell transfer heat from the heavy water reactor coolant on the steam generator primary side to the light water on the secondary side. Details of the secondary side are described in Chapter 5.

The primary side of the steam generators consists of the head, the primary side of the tubesheet and the tube bundle. A partition plate separates the inlet section of the head from the outlet section. The U-tubes are welded to the primary side of the clad carbon steel tubesheet. The head is provided with two access manways, one for the inlet side and one for the outlet side.

The rate of incidence of heavy water leakage from a steam generator is minimized by very high standards in design and manufacture. High recirculation ratios, low heat fluxes, elimination of tube vibration, material selection and both primary side and secondary side chemistry control contribute to long steam generator tube life. When maintenance of the primary side of the steam generator is required, the coolant level in the heat transport system be lowered below the bottom of the steam generators, with coolant circulation and decay heat removal provided by the shutdown cooling system.

The four heat transport pumps are vertical, single-stage, single-suction, single-discharge centrifugal pumps. A heat transport pump is shown in Figure 4.2. The pump casing is of a double-volute design and consists of a vertical bottom suction nozzle, the main bowl, and one horizontal discharge nozzle. The pump cover is mounted on top of the casing and sealed by a double gasket. The cover consists of a bottom flange which mates with the casing and a vertical section housing. The cover consists of a bottom flange which mates with the casing and a vertical section housing the shaft seals.

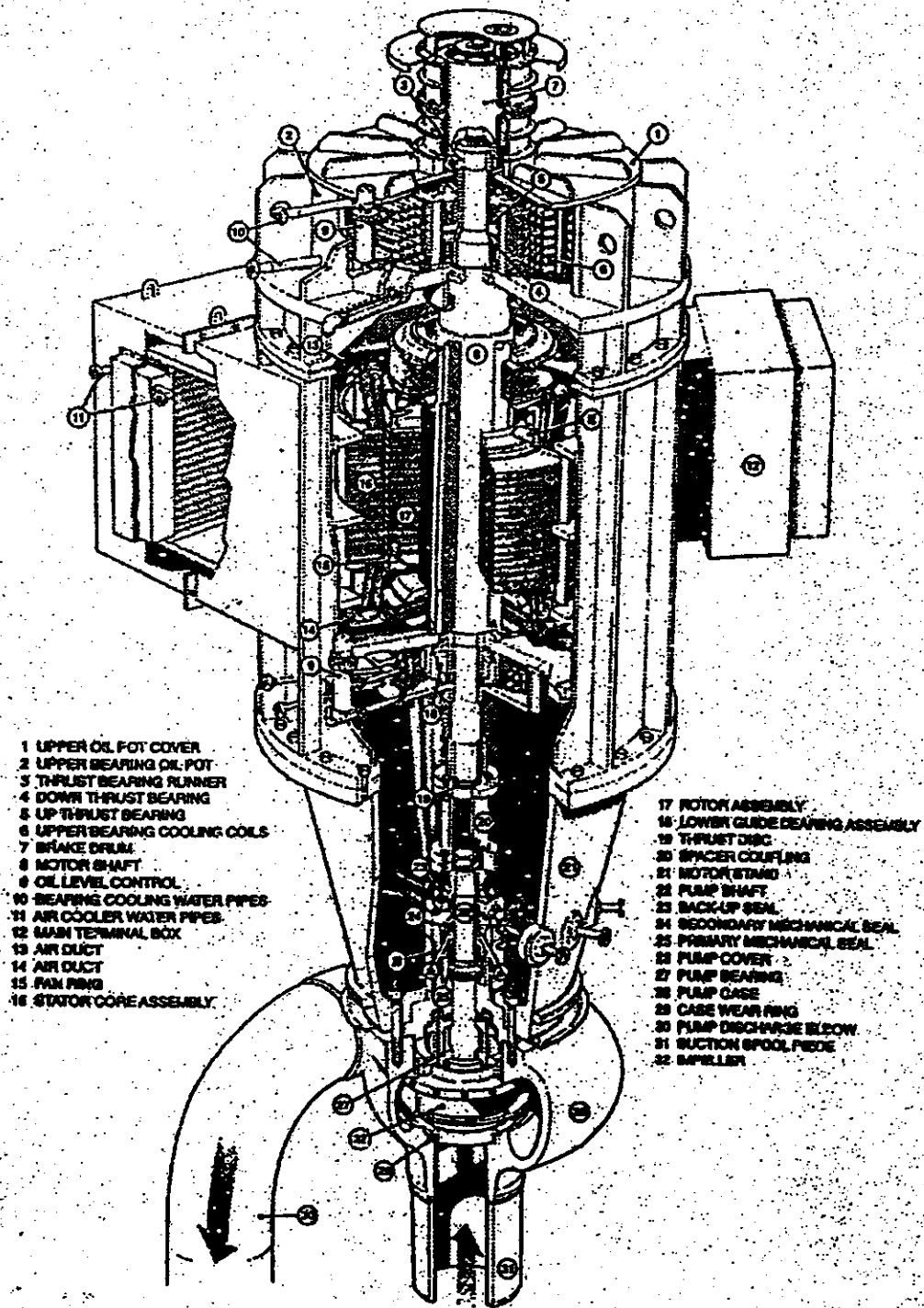

Figure 4.2. Heat Transport Pump.

The pump bearing is located above the impeller. The shaft seals are located above the bearing. The shaft sealing arrangement consists of three mechanical seals and one backup seal in series. Each mechanical seal is designed to withstand the full system pressure. All three rotary seal components are attached to the seal sleeve, which in turn is attached to the shaft. The stationary components are attached to the seal housing which is bolted to a seal flange. In turn, the seal flange is bolted to the pump cover. The backup seal is located at the top of the seal assembly. In the unlikely event that all three mechanical seals fail, the backup seal prevents significant leakage of heavy water to containment while the heat transport system is being depressurized.

When maintenance of the shaft seals or the pump internals is required, the coolant level in the heat transport system is lowered to below the heat transport pumps, while fuel cooling is maintained by the shutdown cooling system.

The pump seal cooling system supplies cooled, filtered, and purified heavy water for lubricating and cooling the mechanical seals. The heavy water is injected below the lowest mechanical seal, at a pressure above pump suction pressure. A small portion of the seal coolant flows upwards through the mechanical seals and the remainder flows downwards into the pump casing. If external gland seal cooling system flow becomes unavailable, heavy water is supplied to the mechanical seals directly from the pump casing.

A leakage recovery cavity, located between the uppermost mechanical seal and the backup seal, routes the normal seal leakage and leakage from a failure of all three mechanical seals, to the leakage collection system.

Each pump is driven by a vertical, totally enclosed, air/water-cooled squirrel cage induction motor. The motor is supported by the motor mount which is bolted to the top of the pump case. A removable coupling connects the motor shaft to the pump shaft. Removal of the coupling allows sufficient space for the pump seals and bearings to be removed without removing the motor.

The pump/motor unit has sufficient rotational inertia, supplemented by inertia packets in the motor so that, on loss of power, the rate of coolant flow reduction matches the power rundown following the reactor trip. Natural circulation maintains adequate cooling of the fuel after the pumps stop.

The motor is equipped with two removable radial bearings and a double-acting thrust bearing. The motor bearings are lubricated by cooled and recirculated oil. An oil lift system, referred to as the jacking oil system, supplies high pressure oil to both sides of the thrust bearing simultaneously, during startup.

Shielding is installed between the pump casing and the pump motor to reduce the irradiation of personnel engaged in pump and motor maintenance and other maintenance tasks above the pump casing.

The power supply for each heat transport pump is normally from the unit service transformer. The motor is able to withstand the supply interruption caused by automatic transfer between the unit service transformer and the station service transformer.

Instrumentation and Control

The heat transport system requires no automatic feedback control devices for proper operation. Flows, pressure differentials and temperature distributions are determined by pump characteristics, line sizes, steam generator characteristics and reactor power level. The instruments connected to the heat transport system are for the control of related systems and the reactor, and are described in detail in other sections.

Instrumentation is provided to monitor and/or control the following:

- Heat Transport Pumps.
 - The pumps are fitted with transducers to measure speed and jacking oil pressure, and to detect vibration. Alarms are annunciated in the control room on high vibration, and on low jacking oil pressure during pump startup.
 - The motor is fully instrumented, and data on oil level on upper and lower oil sumps, bearing temperatures, winding temperatures and current are fed to the distributed control system.
 - The pump motor is tripped on high thrust bearing temperature which could result from a loss of service water.
- Reactor Outlet Header Pressure Measurements for Heat Transport System Pressure Control.
 - Reactor outlet headers carry two sets of pressure measurements.
 - Triplicated measurements are used for narrow-range pressure control of the system during normal operation. A single measurement in each outlet header is used for wide-range pressure control of the system, during warmup of the heat transport system.
- Reactor Outlet Header Pressure Measurements for the Emergency Core Cooling System.
 - After a loss-of-coolant accident and reactor trip, fuel is cooled by injecting water from the emergency core cooling system into the reactor headers. For operation of this system, pressure measurements are taken off each reactor outlet header.
- Reactor Outlet Header Pressure Measurements for Heat Transport System Overpressure Protection, and for shutdown system number 1 and shutdown system number 2.
 - Each reactor outlet header carries triplicated pressure measurement loops for each of the safety shutdown systems. These signals are also used to open the two liquid relief valves on high system pressure.
- Header Level Measurements.
 - During repair or inspection of a heat transport pump or steam generator the heat transport system coolant is drained to a level just above the headers and fuel cooling is maintained via the shutdown cooling system. Coolant level is maintained within a range that provides adequate coolant level above the reactor inlet feeder inlets, and avoids starving the shutdown cooling pumps.
- Gross Low Flow Trip System.
 - Gross low flow is detected by triplicated flow measurements. Shutdown systems number 1 and number 2 trip the reactor when certain combinations of feeder flow measuring elements detect low flow.

4.2 HEAT TRANSPORT PRESSURE AND INVENTORY CONTROL SYSTEM

The heat transport pressure, and inventory control system performs the following functions:

- Controls the pressure and heavy water inventory in the heat transport system for all normal operating conditions.
 - Limits pressure increases and decreases in the heat transport system due to various operating transients to acceptable values.
 - Accommodates heat transport system coolant swell and shrinkage associated with warmup, cooldown, power maneuvering and other unit disturbances.
 - Provides for suitable heat transport system pressure recovery following sudden pressure reduction due to power reduction, such as a trip or a stepback.
 - Limits pressure reduction in the heat transport system due to sudden depressurization of the secondary side of the steam generators.
 - Provides overpressure protection for the heat transport system for all modes of operation and a means of containing any relief from the heat transport system in the short term.
- Provides adequate net positive suction head for the heat transport heavy water feedpumps during normal reactor operation.
- Provides the heat transport pump glands and the fuelling machines with a cool and purified heavy water supply flow.
- Minimizes outflow of heat transport coolant due to the failure of associated valves.
- Provide the heat transport purification system with a cool heavy water flow.
- Transfers heavy water from the heat transport system to the heavy water supply storage tanks via the heavy water storage tank when maintenance of heat transport system equipment, requiring partial draining of the heat transport system, is undertaken.
- Provides light water make-up to compensate for a small loss-of-coolant accident, if normal D₂O makeup is depleted or unavailable.
- Provides a means of degassing the heat transport system coolant.
- Provides a process parameter (pressurizer level) for safety system action (shutdown systems number 1 and number 2).

A simplified flowsheet of the system is shown in Figure 4.3. The pressurizer is connected to the main heat transport system at one of the steam generator inlet lines by the pressurizer connection line. A valve is provided to isolate the pressurizer from the heat transport system during maintenance shutdowns.

The heavy water in the pressurizer is heated by electric heaters if the liquid's temperature falls below the desired saturation temperature. During heat transport system warmup, the heaters are used to increase the pressure in the pressurizer.

The cushioning effect of the heavy water steam volume in the pressurizer is supplemented by pressurizer spray when the pressure rises above a setpoint. The spray flow is supplied from the discharge of the heavy water feedpumps. Two steam relief valves are provided for overpressure protection of the pressurizer when it is isolated from the heat transport system.

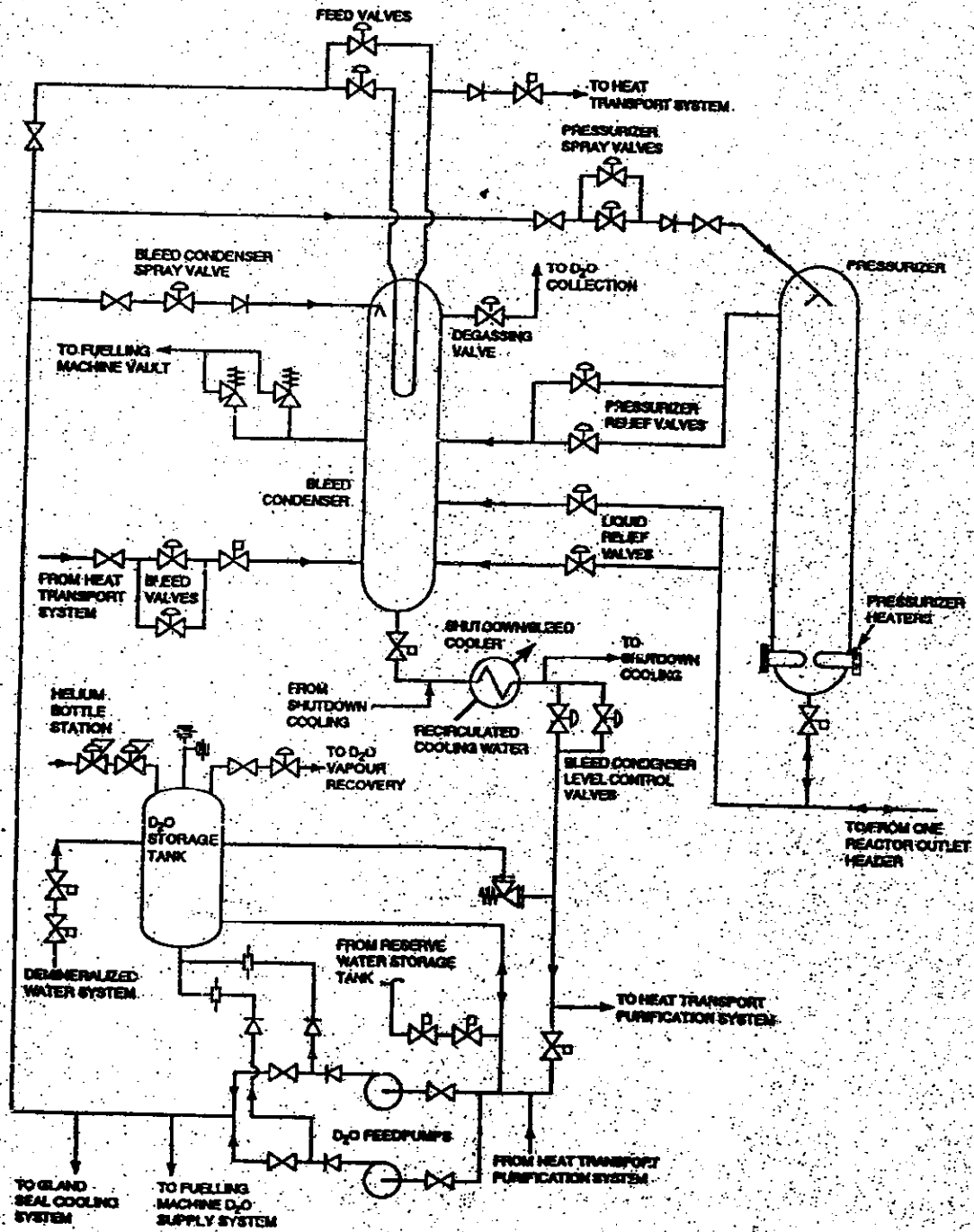

Figure 4.3. Heat Transport Pressure and Inventory Control System.

The pressurizer stores the heavy water displaced by the change in volume of the reactor coolant in the heat transport system during warmup and startup from 100°C to full power. The pressurizer level setpoint increases with heat transport system temperature during warmup and with reactor power during startup to accommodate the volume change between zero power cold and full power. The heavy water level is automatically controlled at the setpoint by the heavy water pressure and inventory control system under the control of computers.

Vapourization of part of the saturated liquid heavy water stored in the pressurizer minimizes the pressure decrease caused by the outflow of heavy water following a reduction in reactor power. The pressure is restored to the setpoint by the electric heaters.

When the reactor is at low power and the heat transport pumps are shut off, the pressurizer may be isolated from the heat transport system. In this case, the pressure control of the heat transport system is achieved by feed and bleed. This is called 'solid mode' operation.

Feed and Bleed Circuit

Inventory control (or pressure control during the solid mode) for the heat transport system is achieved by feed and bleed.

Bleed flow is taken from the suction of one of the heat transport pumps and discharged into the bleed condenser via the bleed valves as two phase flow. The steam is condensed in the bleed condenser by a reflux cooling tube bundle with cooling flow from the feed flow. The tube bundle recovers part of the heat from the bleed flow. The bleed flow is then further cooled by the shutdown/bleed cooler before entering the heat transport purification system via the bleed condenser level control valves. The shutdown/bleed cooler is isolated from the shutdown cooling system during reactor operation by two motorized valves (refer to Section 2.6 for more details on the shutdown/bleed coolers). The bleed condenser level control valves maintain the heavy water level in the bleed condenser at the setpoint.

One heavy water feedpump is normally operating and takes water from the heavy water storage tank and/or the heat transport purification system. It supplies the required flow through feed control valves to the heat transport system via the heat transport pump suction line.

The signal to feed or bleed heavy water to or from the heat transport system is based on the pressurizer level during power operation, and on reactor outlet header pressure during 'solid mode' operation with the pressurizer isolated.

The heavy water feedpump also provides:

- a cool spray flow to the pressurizer for pressure control,
- a cool spray flow to the bleed condenser for pressure control,
- cool heavy water to the fuelling machine heavy water supply system, and
- a cool flow through the bleed condenser reflux tube bundle for heat recovery.

Storage and Transfer Circuit

The heavy water storage tank, which is connected to the suction side of the heavy water feedpumps, serves as the head tank for the pumps. During initial warmup to 100°C, the heavy water swell from the heat transport system is accommodated in the heavy water storage tank. This volume of heavy water provides more than 30 minutes of feed flow, for heat transport pump gland cooling in the event of loss of bleed flow. Heat transport pump seal cooling return flow and feedpump recirculation flow circulates through the heavy water storage tank before returning to the heavy water feedpump suction. Helium is used as cover gas for the heavy water storage tank.

The heavy water storage tank is connected to the heavy water transfer system by a line with a normally closed valve. This line is used to transfer heavy water to and from the heavy water storage tank. Transfer is required typically during a maintenance shutdown, when it is necessary to partially drain the heat transport system to service the steam generators and/or the heat transport pumps.

Following a small leak in the heat transport system, operator action can be initiated to supply make-up to the heat transport system. Make-up water is drawn from the reserve D₂O inventory at the station (including downgraded D₂O) and transferred to the D₂O storage tank. If the leak cannot be stopped before the D₂O reserve is exhausted, light water make-up from the reserve water tank can be valved in to provide light water make-up to the suction side of the heavy water feed pumps.

Instrumentation and Control

The pressure and inventory control system includes flow, level, pressure and temperature measurement and control loops which provide pressure and inventory control for the heat transport system. The most important parameters to be controlled are described in the following sections.

Normal (or Narrow-Range) Heat Transport System Pressure Control

The heat transport system pressure is controlled by condensing steam or by heat addition to the pressurizer, utilizing the pressurizer spray or the heaters at the bottom of the pressurizer respectively, under normal power-producing operation.

Triplicated sets of pressure measurements taken from the reactor outlet headers are used for heat transport system pressure control. The control system selects the reactor outlet header that has the highest pressure and controls this pressure to the desired value. This is done by feeding all the outputs of the pressure transmitters into the distributed control system. The median pressure on each header is determined, and the higher of the median pressures is compared with the system setpoint. If the pressure is above the setpoint, the spray valves on the pressurizer open to reduce pressure and, if below the setpoint a heater in the pressurizer is turned on to increase pressure. This pressure control system operates on a narrow-range transmitter signal for greater accuracy.

The variable heater is used under normal steady state conditions. The on-off heaters come on when the pressure drops below the proportional control band setting of the pressure

controller. The on-off heaters also come on if the water temperature falls a predetermined amount below the normal saturation value.

Wide-Range Pressure Control.

During 'solid mode' feed and bleed pressure control operation, the pressurizer is isolated from the heat transport system. In this case the wide-range pressure control system is used. This is a single-channel system and uses signals from pressure transmitters located on the reactor outlet headers. The higher of the reactor outlet header pressures is selected and is compared to the setpoint. The output from the distributed control system is fed to the two feed valves and the two liquid bleed valves which control heat transport system pressure. The wide-range pressure control is not used above 5% reactor power.

When isolated, the pressurizer pressure is controlled by a single-channel pressure control loop which controls the spray valves and the heaters. Overpressure protection is provided by two pressure relief valves on the pressurizer.

Pressurizer Level (Inventory Control) and Temperature Control.

The level in the pressurizer when connected to the heat transport system is controlled via the feed and bleed valves. Triplicated level measurements are fed to the distributed control system where the median is calculated. The level setpoint is programmed as a function of heat transport system reactor inlet header temperature, reactor outlet header pressure and reactor power.

During increases in reactor power, the pressurizer accommodates the resultant heat transport system swell. The water flowing into the pressurizer is below the saturation temperature. This condition is sensed by temperature detectors in the pressurizer and the heaters are turned on to increase the water temperature to the saturation value. The rising water level compresses the vapour space above the water and pressure is maintained at the setpoint by the spray valves. The pressurizer heaters are shut off automatically on low pressurizer water level.

Bleed Condenser Level and Pressure Control.

Level in the bleed condenser is controlled via the distributed control system. Two 50 percent capacity level control valves regulate the outflow from the bleed condenser to maintain a constant level in the bleed condenser.

Pressure in the bleed condenser is controlled via the distributed control system. Pressure is regulated by condensing the vapour in the bleed condenser with cooling flow through the reflux tube bundle and a spray flow supplied from the heavy water feedpumps. The reflux bundle flow and the spray flow are regulated by control valves as demanded by the pressure controllers.

Shutdown/Bleed Cooler Temperature Control

Control of the cooler outlet temperature is performed via the distributed control system. The downstream heavy water temperature must be sufficiently low to ensure feedpump net positive suction head and to avoid damage to the ion exchange resin and to the glands of the heat transport pumps. Overtemperature protection is provided by override controls, which close the bleed condenser level control valves on high temperature at the cooler outlet.

4.3 SHUTDOWN COOLING SYSTEM

The major functions of the shutdown cooling system are to:

- a. Cool the heat transport system after a reactor shutdown and following an initial cooldown by steam rejection, to a temperature suitable for maintenance.
- b. Maintain the heat transport system temperature at the maintenance level for any desired length of time.
- c. Provide a means of draining, refilling and level control of the heat transport system to allow maintenance of the heat transport pumps or steam generators.
- d. Cool down the heat transport system from the zero power hot temperature under abnormal conditions.
- e. Provide a long term heat sink after a design basis earthquake, following depletion of Group 2 feedwater to the steam generators.

A simplified flowsheet of the shutdown cooling system is shown in Figure 4.1.

The system consists of two circuits, one located at each end of the reactor. Each circuit consists of one pump, one heat exchanger, valves and piping. Since the heat transport system layout at each end of the reactor features two inlet headers and one outlet header in a single loop arrangement, the symmetry provides good flow distribution during normal shutdown operation.

In each circuit, the pump takes suction from reactor outlet header and discharges via the heat exchanger into the two inlet headers at the same end of the reactor. The design pressure and temperature for the shutdown cooling system are compatible with the heat transport system. The system is normally full of heavy water and isolated from the heat transport system by the header isolation valves.

One of the coolers, called the shutdown/bleed cooler, carries out the dual functions of shutdown cooling and bleed cooling. A small isolation valve, called the warmup valve, is located in parallel with one of the inlet header isolation valves. This valve is used for warming the shutdown cooling system. Cooling water to both heat exchangers (shutdown/bleed cooler and shutdown cooler) is provided by the recirculated cooling water system. The shutdown cooler is provided with seismically qualified Group 2 raw service water backup cooling supply, which can be initiated if the normal recirculated cooling water supply fails. This improves the shutdown cooling system reliability as a heat sink, following a DBE and when the steam generators are drained during maintenance.

There are two bypass lines; one bypassing the pump/heat exchanger and another bypassing the pumps only. Both lines have a motorized valve for isolation. The pump/heat exchanger bypass line is used to moderate the cooling efficiency of the heat exchangers. The pump bypass allows the shutdown coolers to be used with the heat transport pumps when the shutdown cooling pumps are unavailable.

For normal heat transport system cooldown, steam from the steam generators bypasses the turbine and flows into the turbine condenser to reduce the heat transport system temperature from the hot shutdown temperature to 177°C in approximately 30 minutes.

Cooldown from 177°C to 54°C or below is achieved using the shutdown cooling system. Initially all motorized valves in the system are closed. The bleed condenser is isolated before switching from steam generator to shutdown cooling for cooldown. The outlet header isolation valves are opened to pressurize the system and ensure adequate NPSH. The heat transport pumps are shut down and the shutdown cooling pumps are started. The isolation valves to both heat exchangers and the pump/heat exchanger bypass valve are opened. The warmup valves are opened to allow warmup of the shutdown cooling piping. The inlet header isolation valves are then gradually opened. Both coolers are valved in for cooldown and the pump/heat exchanger bypass valve is maintained in a partially open position to prevent the cooldown rate from exceeding the design rate of 2.8°C per minute.

When the shutdown cooling system is in the long-term cooldown mode with both shutdown cooling pumps operating and with the heat transport system full, part of the shutdown cooling flow bypasses the core through the steam generators and pumps. In the event of failure of one of the shutdown cooling pumps, the reactor outlet header temperature increases slightly but does not result in boiling in any of the fuel channels.

For steam generator or pump maintenance, or inspection requiring the opening of the pressure boundary, the heat transport system coolant is drained to near the header level. The heavy water removed from the heat transport system is sent to the heavy water storage tank. Under this operating condition, all the shutdown cooling system flow goes through the core. Manual feed and bleed is used to control the heavy water level in the heat transport system. If one pump fails under this condition, header water level changes are within an acceptable range. The heavy water feedpumps are used to refill the heat transport system.

With recirculated cooling water available, the shutdown cooling system can be used to cool the heat transport system from 260°C for a limited number of cycles. The cooldown procedure is similar to that of normal cooldown using the shutdown cooling pumps, with the exception that only one heat exchanger is valved in initially. The second heat exchanger is valved in at a lower temperature.

Under abnormal conditions, such as loss of both shutdown cooling pumps, the shutdown cooling system can operate under the heat transport pump mode. In this mode, the shutdown cooling system pumps are off, the pump bypass valve is opened and coolant flow is driven through the shutdown coolers by the heat transport pump, from the inlet header to the outlet header.

The shutdown cooling system can be valved in as a long term heat sink after a design basis earthquake. The shutdown cooler is provided with seismically qualified Group 2 raw service water as a backup to the normal recirculated cooling water supply. The recirculated cooling water isolation valves to the heat exchanger are closed before raw service water is valved in.

4.4 HEAT TRANSPORT AUXILIARY SYSTEMS

Heat Transport Purification System

The heat transport purification system performs the following functions:

- Minimizes buildup of radioactive corrosion products in the heat transport circuit.
- Minimizes the concentration of fission products released from fuel defects into the heat transport coolant.
- Assists in maintaining proper pH (pD) control of heat transport coolant.
- Provides for purification during normal reactor operation and during initial stage of shutdown and cooldown (whenever the heat transport pumps are operating).
- Provides a source of clean heavy water for heat transport system makeup.
- Suppresses oxygen generated from radiolysis of heavy water by the addition of hydrogen.

The purification system is a low pressure and low temperature system. The bleed valves are conditioned by a biased signal which provides the required purification flow into the bleed condenser. The pressure in the bleed condenser provides the head to circulate the flow through the purification circuit. The purification flow passes through cartridge filters and ion exchange columns before routing to the heavy water feed pump suction. A bypass line connects the heavy water feed pump suction to the outlet side of the shutdown/bleed cooler to provide a bleed path when the purification system is isolated. To evaluate the performance of the system, coolant samples are taken at the outlets of the cooler, filter and each ion exchange column.

The maximum purification flow rate is based on a purification half-life of approximately one hour. During normal operation, purification flow is reduced to provide a purification half life of four hours. (The purification half-life is the time taken to reduce the concentration of dissolved solids by 50 percent, assuming no addition of solids.)

The purification system functions during normal reactor operation to limit activity and corrosion product buildup in the coolant by removing soluble and insoluble impurities and by maintaining the pH_A (apparent pH) of the heavy water at the required value. It also removes soluble and insoluble impurities following a sudden increase caused by a chemical, hydraulic or temperature transient. In this manner, the activity buildup caused by activated corrosion products is minimized. Hydrogen is added via the purification system to suppress oxygen generated by the radiolysis of heavy water.

Corrosion products deposit on piping surfaces throughout the heat transport system. These products move around the system in both ionic and particulate forms, being released from surfaces, transported some distance and then deposited elsewhere. The recommended coolant alkalinity inhibits the deposition of corrosion products on the fuel surfaces, thus minimizing activation. This minimizes the contribution made by activated corrosion products to radiation

fields and, hence, to the radiation dose to operating personnel. The purification system assists in maintaining proper pH_A of the coolant through the use of mixed-bed resin with the cation resin portion being in the lithium form (Li^+). The ion exchange resin releases lithium ions which slowly raises the heat transport pH_A as cation impurities are removed. Alternatively, use of deuterium-form cation resin reduces the lithium concentration and also the pH_A .

The purification system assists by removing corrosion products both before and after their activation and by removing fission products, notably iodine and cesium which may be released from fuel defects.

Heat Transport Heavy Water Collection System

The heat transport heavy water collection system performs the following functions:

- Collects heavy water leakage from double-packed valve stems, pump seals and inter-gasket cavities during reactor operation.
- Collects heavy water drainage from equipment before performing maintenance.
- Provides a means of venting equipment containing heavy water.
- Provides for sampling to determine the D_2O isotopic and chemical impurity concentrations.
- Cools and transfers the collected heavy water, if of reactor grade isotopic, to the heat transport pressure and inventory control system.
- Transfers the collected heavy water, if not of reactor grade isotopic, to the heavy water cleanup system.
- Provides for monitoring of the heavy water leakage and drainage flows.
- Provides alarm upon detection of water in the heat transport pump motor stand drains line and on the heavy water collection tank support floor.
- Provides a means for condensing degassing flow from the heat transport system and to vent off non-condensables to the reactor building ventilation system.
- Provides tank level indication and alarm to avoid D_2O going up the vent line during a period of abnormally high leakage collection.

4.5 HEAT TRANSPORT SYSTEM OPERATION

System Warmup

Following a prolonged shutdown, the heat transport system could be at atmospheric pressure and at ambient temperature. The heat transport system coolant may be drained to near the header level or it may be completely filled. The heat transport pumps are stopped and cooling is provided by the shutdown cooling system. The pressurizer is partially filled with heavy water and is isolated from the heat transport system.

In preparation for system warmup, the heat transport system must be refilled if it has been partially drained and then put on 'solid mode' pressure control. The main circuit can be pressurized by the heavy water feedpumps.

The initial stage of warmup involves activating the pressurizer heaters which results in a gradual increase in pressurizer temperature and pressure. The pressurizer isolation valve is opened and heat transport pressure control is transferred to the normal mode prior to startup of the heat transport circulating pumps.

The next step of warmup involves stopping both shutdown cooling pumps and closing the shutdown cooling/reactor outlet header isolation valves. The heat transport pumps are started. The system is warmed up by pump heat and low reactor heat. The shutdown cooling/reactor inlet header isolation valves are closed when the heat transport temperature reaches 177°C and normal bleed is established via the bleed condenser and bleed valves. System swell up to 100°C is stored in the heavy water storage tank. The swell during the remaining warmup period is accommodated in the pressurizer. The heat transport system is pressurized in steps as the system temperature increases.

Startup

After warmup, the heat transport system coolant temperature and pressure at the outlet header are the zero power hot values. The pressurizer is hot and pressurized and is connected to the main heat transport circuit. Raising of reactor power can now begin.

The design maneuvering rates are:

Power Range	Maximum Rate
0 - 25 percent of full power	4 percent of actual power per second
25 - 80 percent of full power	1 percent of full power per second
80 - 100 percent of full power	0.15 percent of full power per second

As reactor power increases, the reactor outlet header pressure rises as a result of the swell in the system. Thus heavy water is forced into the pressurizer compressing the vapour phase. The control system corrects the mismatch between the actual and the desired pressure of the pressurizer by condensing steam in the pressurizer utilizing the heavy water spray. As the reactor power is increased, the level setpoint in the pressurizer increases automatically so that all the swell resulting from power increases is stored in the pressurizer.

Full Power Operation

During normal operation the pressure and inventory control system controls the heat transport system inventory by maintaining the pressurizer level at the required value. The heat transport system pressure is controlled by maintaining the heavy water vapour space in the pressurizer at the desired pressure.

Shutdown

The sequence of operation performed during heat transport system shutdown generally follows the startup sequence in reverse, except for one major difference. Whereas startup from zero power hot to full power can be achieved at constant or rising heat transport system pressure, shutdown is accompanied by falling pressure. The reason is that as reactor power is reduced, system shrinkage causes an outflow and, hence, a falling level in the pressurizer. The pressure decrease due to heavy water steam expansion in the pressurizer is acceptable. The net positive suction head available for the heat transport pumps is adequate at all times.

Cooldown

Cooldown of the main circuit from zero power hot to 177°C is achieved by discharging steam from the steam generator secondary side through the condenser steam discharge valves to the condenser or, in case of loss of condenser vacuum, to the atmosphere via the atmospheric steam discharge valves.

Below 177°C the shutdown cooling heat exchanger becomes the heat sink and circulation is provided by the shutdown cooling pumps. Heat transport pumps can be used for circulation if the shutdown cooling pumps are not available. The bleed condenser is isolated and the bleed condenser level control valves take over the function of the bleed valves.

Under abnormal conditions, the shutdown cooling system can achieve cooldown from zero power hot conditions.

The system is depressurized in steps as the system temperature decreases. The system is under 'normal' mode pressure control until the heat transport pumps are shut down, to minimize the chance of pump cavitation due to a sudden depressurization. Once the heat transport pumps are shut down, the operator has the option to continue cooldown in 'normal' mode or switch to 'solid' mode control.

When the heat transport system temperature falls to 54°C, the heat transport system may be depressurized and the coolant level lowered to near the header level. The coolant is removed via the shutdown cooling system and transferred to the heavy water storage tank. To assist in removing coolant from the heat transport system, nitrogen is added through the heat transport pump seal cavity.

If a short shutdown is expected it is desirable to isolate the pressurizer and maintain it pressurized, since heating the pressurizer takes much longer than heating the heat transport

system. If an extended shutdown is planned, the pressurizer will usually be isolated from the heat transport system and depressurized with the pressurizer heaters switched off. Heat transport system pressure control is under 'solid' mode.

Degassing

After the heat transport system is refilled following maintenance, it will have a high concentration of nitrogen. The concentration of nitrogen can be reduced by opening the degassing valve which discharges to the heavy water collection tank. The steam is condensed by a spray flow in the heavy water collection tank and the gas effluent is discharged to the reactor building ventilation system via the vapour recovery system.