

KANUPP – IAEA Training

ECC and Dousing Systems Chemistry Control

ECC/Dousing System

Course Objectives

- State the purpose of the Emergency Core Cooling System.
- State the three modes of ECC operation. Briefly describe each of these modes of ECC operation.
- List the main chemistry parameters monitored in the ECC System and for each of these parameters, state why each of these parameters are monitored.
- Locate in the field the main components of the ECC System.
- Identify in the field the chemical addition locations for the HPECC & MPECC Systems.

ECC/Dousing System

Course Objectives

- State the purpose of the Dousing System.
- State the purpose of Chemistry Control of the Dousing System.
- Locate in the field the chemical addition point for the Dousing System.
- Demonstrate the correct procedure that would be used to add chemicals to the Dousing, HPECC & HPECC Systems.

Emergency Core Cooling

System Purpose

- Provides cooling flow to the fuel inside the core in the event of a Loss of Coolant Accident (LOCA) in the Primary Heat Transport System. The ECC system must be capable of preventing significant fuel failures following a LOCA of any size at any location. The ECC System will remove residual and decay heat from the reactor core in order to limit fuel damage.

Emergency Core Cooling System

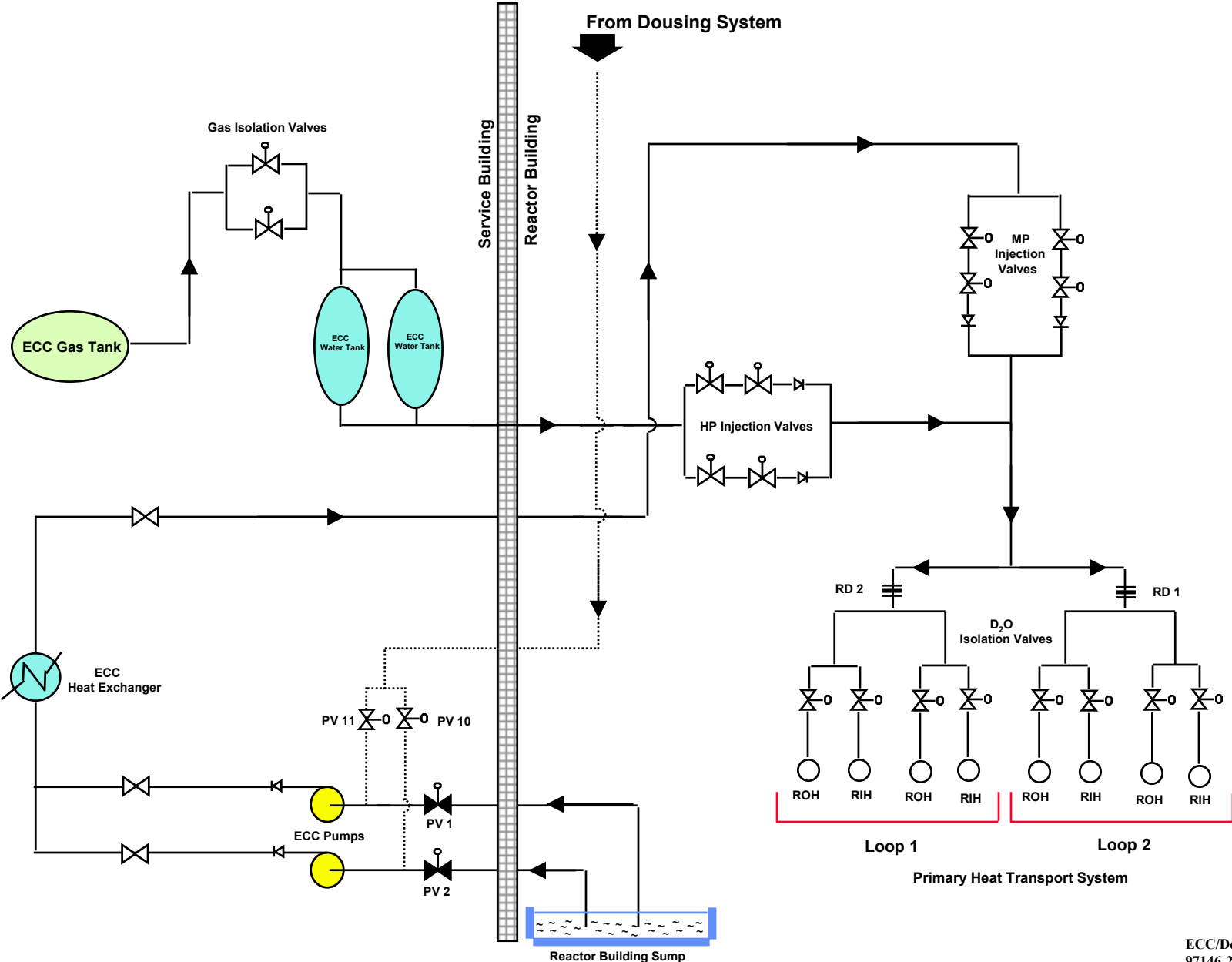

Emergency Core Cooling

- **Emergency Coolant Injection**
 - Light water injected into the Heat Transport System via three stages - High, Medium & Low Pressure Injection.
- **Heat Transport Loop Isolation**
 - Isolates the failed Heat Transport loop from the unfailed loop. ECC injection is made to the failed loop (also some to the unfailed loop due to initial pressure reduction in the unfailed loop) The HTS loops are connected via the pressurizer, feed system, crossover lines & purification system. Isolation of these systems will isolate each loop from each other. This will ensure that sufficient inventory remains in the unruptured loop to promote sufficient cooling by thermosyphoning.
- **Steam Generator Crash Cooldown**
 - Required in order to reduce the transfer of heat from the Secondary Side to the Primary Side. MSSV's are opened to reduce boiler pressure and thus reduce temperature. The boilers act as a "Heat Sink" during ECC operation.

Emergency Core Cooling

Stages of Operation

- **High Pressure Injection**

- Water from two (2) tanks injected into the Heat Transport system. Water forced into the system using high pressure air (backed up by a nitrogen supply).

- **Medium Pressure Injection**

- Water from the Dousing Tank injected into the Heat Transport System by one (1) of two (2) ECC pumps.

- **Low Pressure Injection**

- Water from the Reactor Building Basement (R/B Sump) is circulated from the floor into the Heat Transport System using the ECC pumps.

Emergency Core Cooling

High Pressure Injection

- Initiation of ECC is triggered when HTS pressure drops to 5.5 MPa. When this occurs, HTS loop isolation and steam generator crash cooling begins.
- Water from the two tanks is forced into the failed HTS loop when the failed loop pressure falls below 4.14 MPa (600psig). The ECC Helium Tanks is pressurized to 4.14 MPa. Pressure in the unfailed loop also drops to below 4.14 MPa due to boiler crash cooling - once loop pressure rises above 4.14 MPa, injection will stop.
- For a 100% Header Break, total injection time is about 2.5 minutes.
- On low tank levels, the H.P. Injection valves automatically close in order to prevent gas from being injected into the HTS circuit.

Emergency Core Cooling

Medium Pressure Injection

- When the water in the injection tanks reaches low level, the H.P. Injection valves close and the valves connecting the Dousing Tank to the ECC pumps open. The M.P. Injection valves will open after a 90 second delay.
- Sufficient coolant contained in the Dousing Tank for a minimum of 13 minutes operation assuming a 100% Header break.
- Upon low Dousing Tank level, ECC pump suction valves to the R/B sump must be opened. Pump Suction valves to the sump (PV1 & PV2) are opened and dousing inlet valves (PV10 & PV11) are closed. Also, the RCW valves for cooling water to the ECC Heat Exchanger are opened to establish cooling water. This is the start of the Low Pressure Injection Stage.

Emergency Core Cooling

Low Pressure Injection

- Water is recovered from the R/B sump and injected back into the failed HTS loop.
- The ECC Heat Exchanger maintains the temperature of the coolant at 49°C. It is estimated that the water in the R/B sump will initially be at about 66°C.
- For small breaks decay heat is transferred to the steam generators and rejected via the main steam safety valves. For larger breaks, the main heat sink will be the break itself.

Dousing System

System Purpose

- To reduce Reactor Building pressure in the event of a LOCA or a Steam Header break.
- Reduces pressure by spraying the building with water. This water will cool the steam and thus reduce the building pressure.
- The Dousing System will operate when the building pressure reaches 14 KPa (2 psig) and stops when pressure falls to 7 KPa (1 psig).

Dousing System

Main Components

- **Storage Tank**

- Concrete Tank which is epoxy lined.
- 2.22×10^6 Kg of demin water maintained at 27°C via heat exchangers cooled by RCW.
- 1.52×10^6 Kg water available for dousing. 0.5×10^6 Kg available for ECC (medium pressure injection). This leaves 0.02×10^6 Kg of water that is not available. Dousing downcomers extend about 2.5 meters into the dousing tank - ECC downcomer extends about 1.2 meters into the dousing tank.
- Plastic vapor barrier in place above tank. Its purpose is to limit air ingress into the dousing water. This plastic barrier will break upon initiation of the dousing system.

- **Piping**

- All piping associated with this system is made of carbon steel. Piping associated with demineralized water make-up and chemical addition are made of stainless steel.

Dousing System

Main Components

- **6 Downcomers**

- Demin water will flow out of these downcomers at a design flowrate of 7245 Kg/s. Flow out of four (4) downcomers is required to reduce peak building pressure - flowrate of 4830 Kg/s.

- **12 Valves**

- Valves go fully open within 5 seconds following a building high pressure alarm.
- Valves go fully closed within 7 to 15 seconds after the R/B pressure falls to 7 KPa (g).
- Valves arranged in series - 2 valves for each downcomer. Arranged into two independent groups (A & B) so that failure of one group will still allow adequate spray distribution in the R/B (every other downcomer operating).

Dousing System

Dousing System

Chemistry Requirements

- Corrosion prevention of Dousing piping during normal plant operation.
- Radioiodine and pH control during dousing.
- Radioiodine control following a dousing incident.

Dousing System

- **Corrosion Control**

- Piping is carbon steel - high pH & reducing conditions required to minimize corrosion.

- **Radioiodine/pH control during dousing**

- Reducing conditions keep the radioiodines in the reduced or ionic form (I⁻ form). This form is not volatile, thus it will remain in the water.
- High pH needed for corrosion control as the water is circulated through the HTS system.

- **Radioiodine control following Dousing Incident**

- Water chemistry must be such that it minimizes the formation of volatile radioiodines - high pH & reducing conditions required.
- The post LOCA may extend for a long time, thus the water conditions must inhibit corrosion of system materials.

