



Heat and Thermodynamics



Introduction



Definitions

- Internal energy
 - Kinetic and potential energy
 - Joules
- Enthalpy and specific enthalpy
 - $H = U + p \times V$
 - Reference to the triple point
 - Engineering unit
 - ΔH is the work done in a process
 - J, J/kg



More Definitions

- Work

- Standard definition $W = f \times d$
- In a gas $W = p \times \Delta V$

- Heat

- At one time considered a unique form of energy
- Changes in heat are the same as changes in enthalpy



Yet more definitions

- Temperature
 - Measure of the heat in a body
 - Heat flows from high to low temperature
 - SI unit Kelvin
- Entropy and Specific Entropy
 - Perhaps the strangest physics concept
 - Notes define it as energy loss
 - Symbol S
 - Units kJ/K , $\text{kJ}/(\text{kg}\cdot\text{k})$
 - Entropy increases mean less work can be done by the system



Sensible and Latent Heat

- Heat transfers change kinetic or potential energy or both
- Temperature is a measure of kinetic energy
- Sensible heat changes kinetic (and maybe potential energy)
- Latent heat changes only the potential energy.



Sensible Heat

$$Q = m \cdot c \cdot (t_f - t_i)$$

- Q is positive for transfers in
- c is the specific heat capacity
- c has units kJ/(kg•C)



Latent Heat

$$Q = m \cdot l_v$$

$$Q = m \cdot l_m$$

- Heat to cause a change of state (melting or vaporization)
- Temperature is constant



Enthalpy Changes

$$Q = m \cdot \Delta h$$

- Enthalpy changes take into account both latent and sensible heat changes

Thermodynamic Properties of H₂O

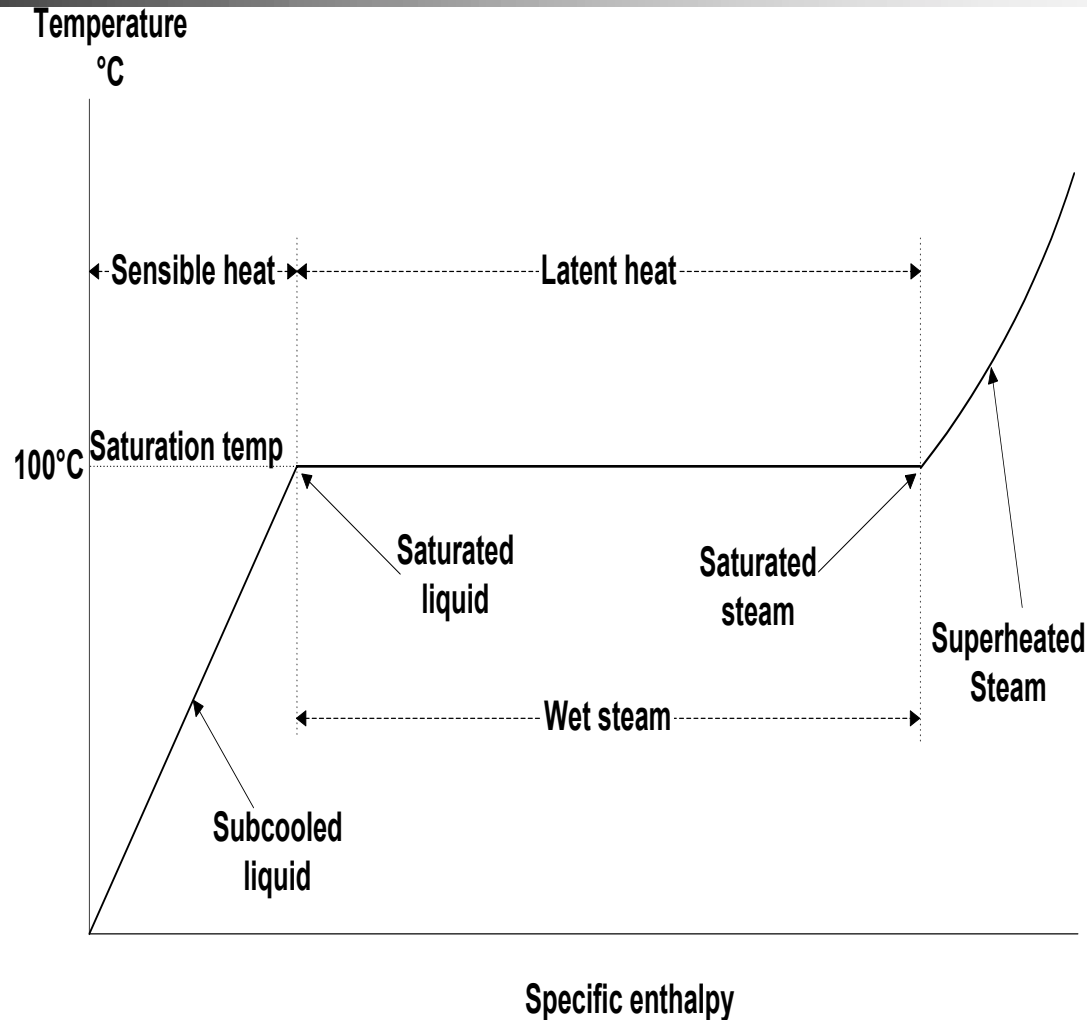

Pressure Effects

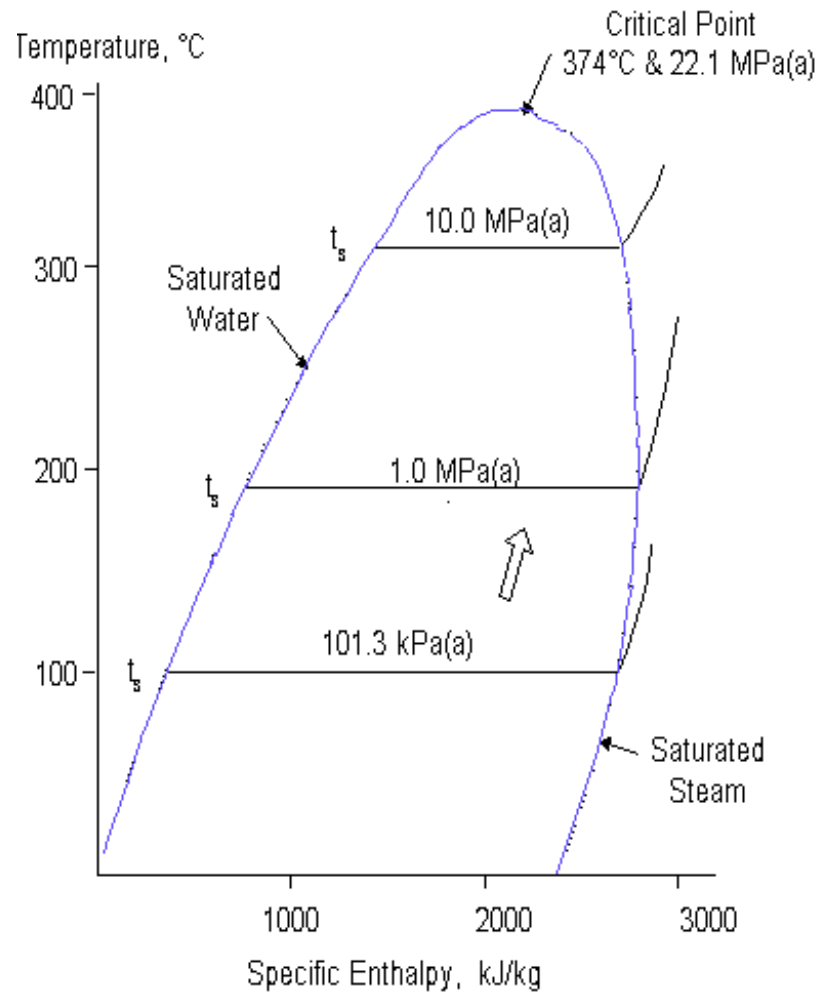



Laws of Thermodynamics

- First Law

- Energy is conserved

- Second Law

- It is impossible to convert all of the heat supplied to a heat engine into work
- Heat will not naturally flow from cold to hot
- Disorder increases

Heat Transfer

Radiation

$$\dot{Q} \propto A \cdot T^4$$

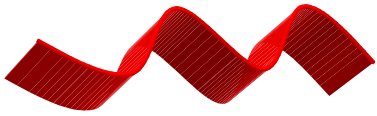

Conduction

$$\dot{Q} = k \cdot \frac{A}{l} \cdot \Delta T$$

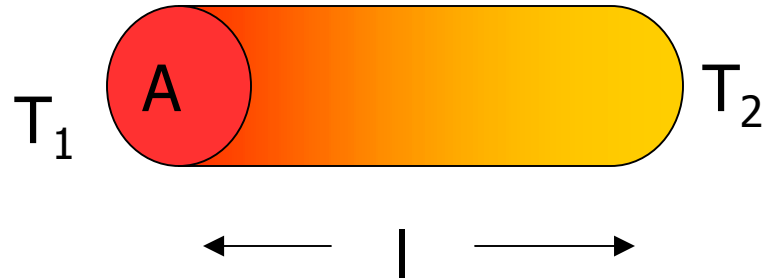

More Heat Transfer

Convection



Mass Flow

$$\dot{Q} = h \cdot A \cdot \Delta T$$

Condensation



Latent heat transfer
from vapor

Dalton's Law



If we have more than one gas in a container the pressure is the sum of the pressures associated with an individual gas.

$$P_c = P_1 + P_2 + P_3 + \dots$$

Condensing Heat Exchanger

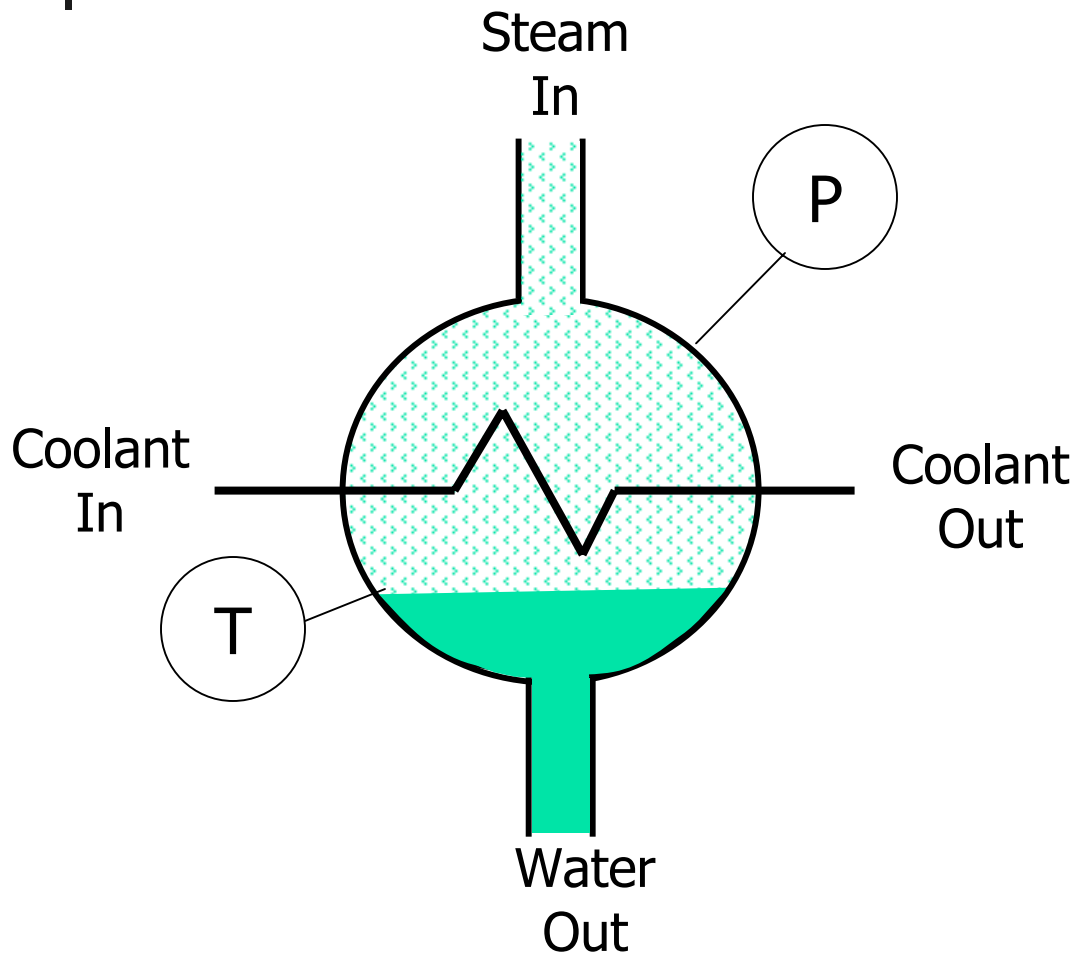

$$P = P_{\text{saturation}}$$
$$T = T_{\text{saturation}}$$

Non-Condensables in Heat Exchanger

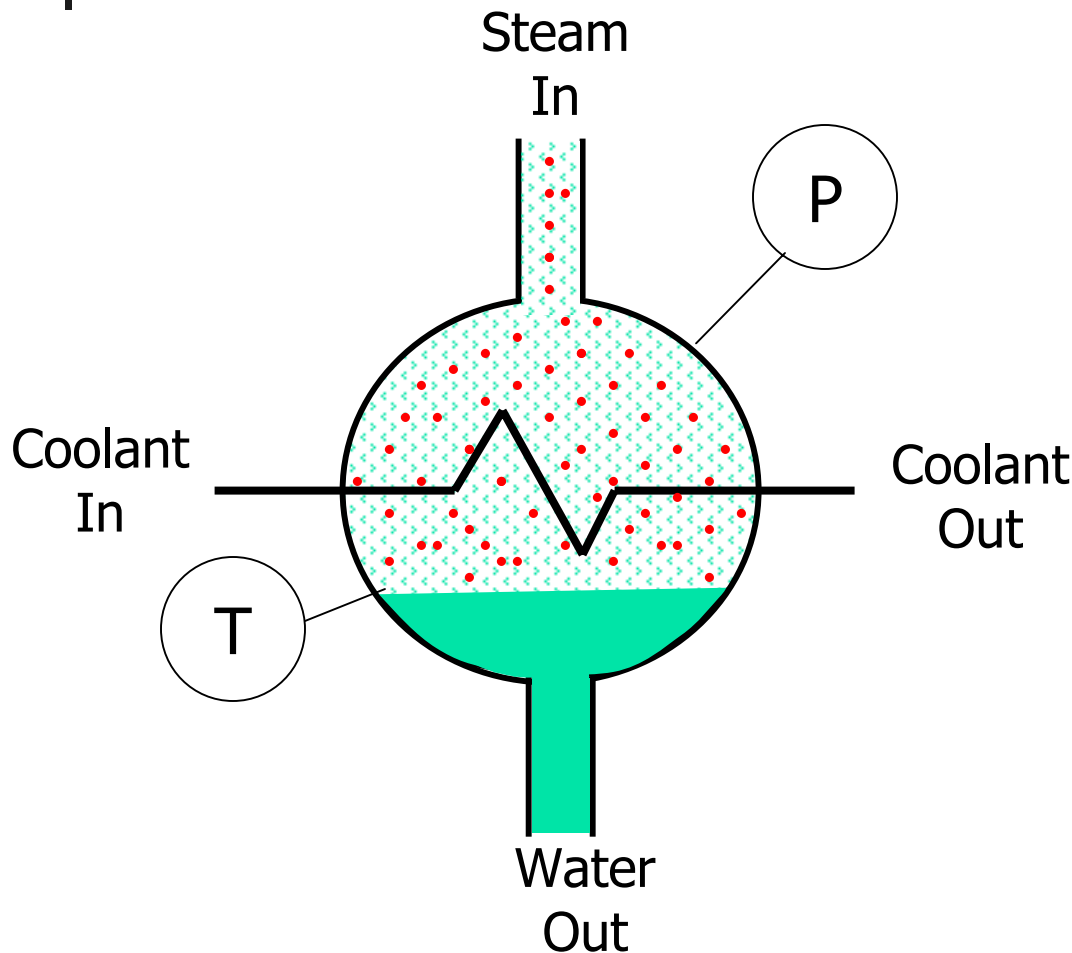

$$P = P_{\text{saturation}} + P_g$$
$$T = T_{\text{saturation}}$$

Condenser Appears
Subcooled



For You to do

QUESTIONS



HTS Normal Operation

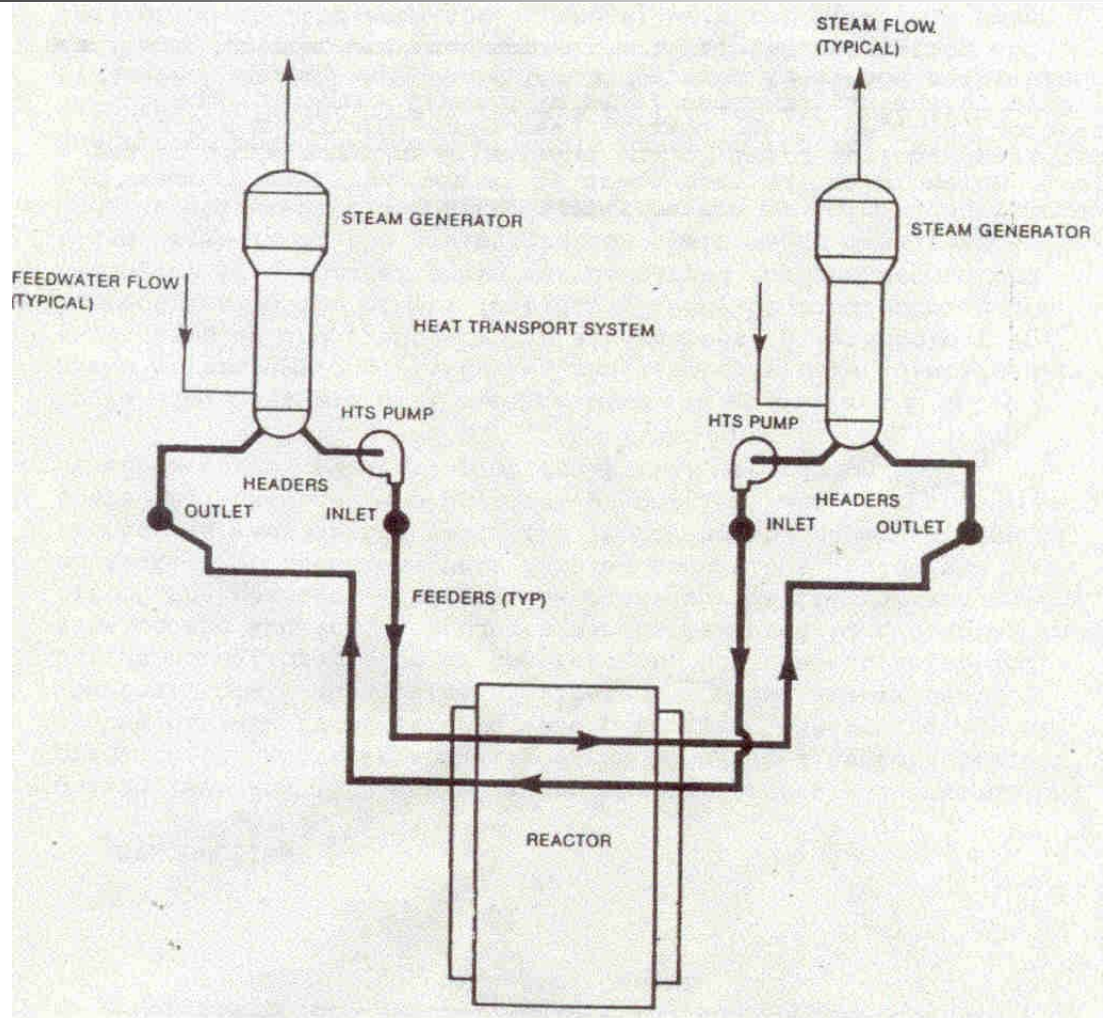

Reactor Thermal Power

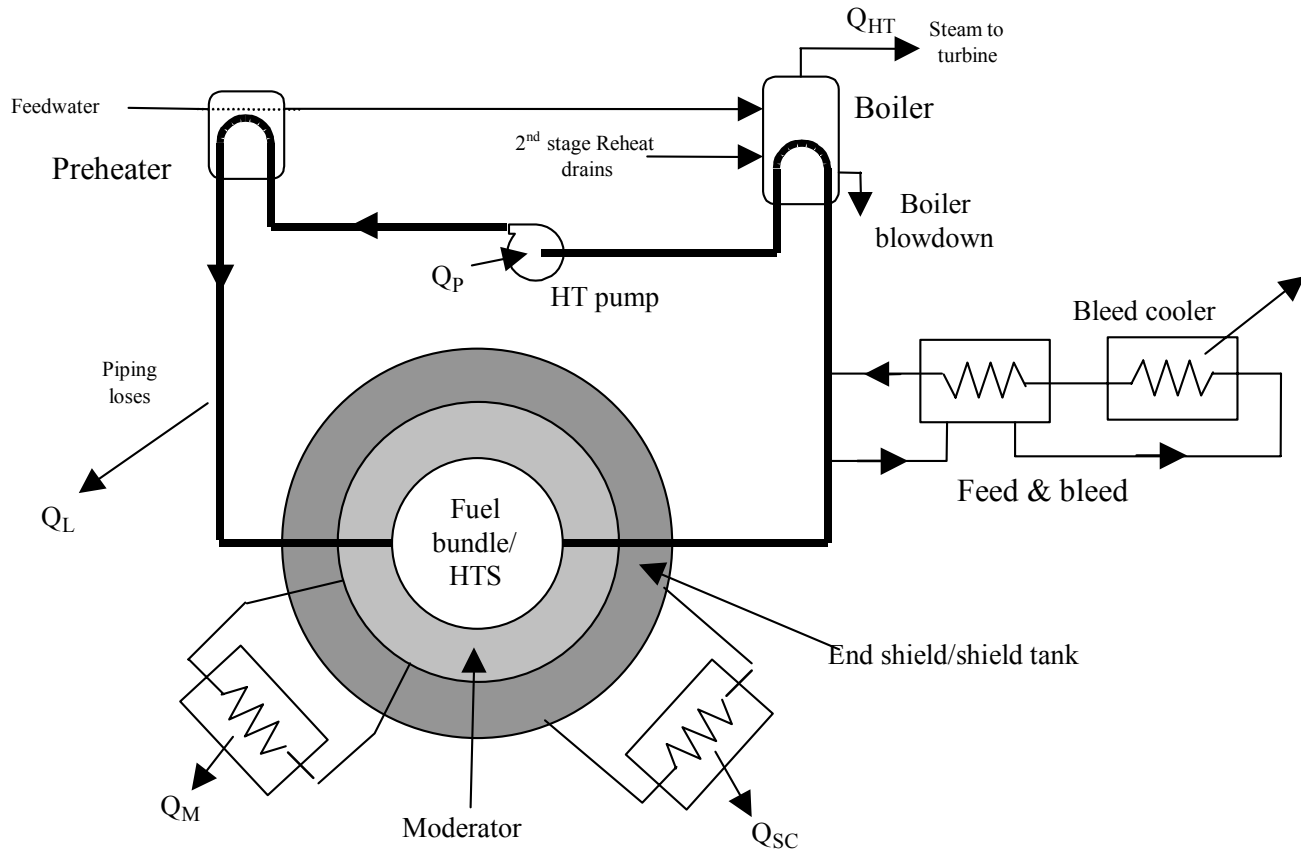



Reactor Power and ΔT

- ΔT is an indicator of reactor power if boiling is not taking place

$$\dot{Q} = \dot{m} \cdot c \cdot \Delta T$$

- At boiling ΔT stops changing
- In boiling channels total enthalpy increase must be calculated



Fuel Safety

- No overpowering
- Adequate cooling

Fuel Heat Transfer

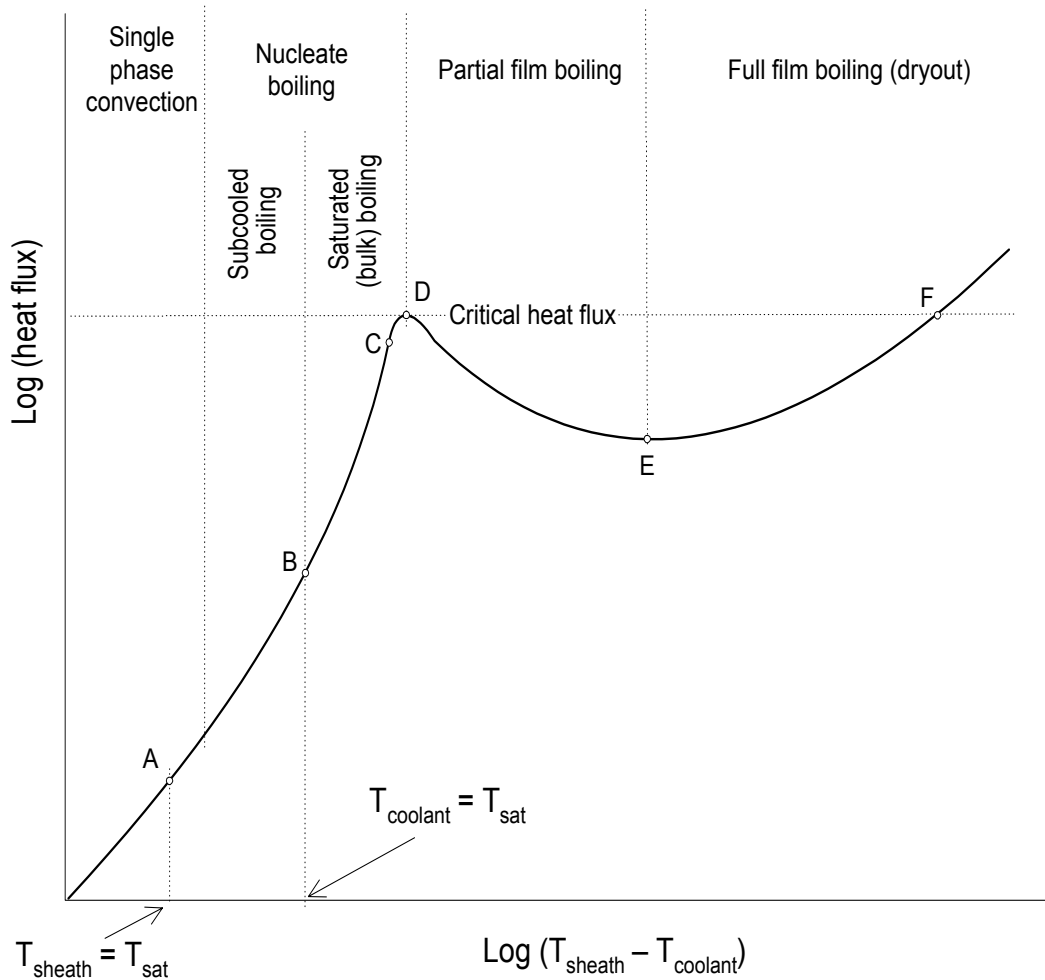



Two new terms

- Critical Heat Flux
 - CHF
 - The maximum heat flux nucleate boiling can transfer
- Dryout
 - When dry patches of vapor exist on the fuel sheath

Uniform Heating

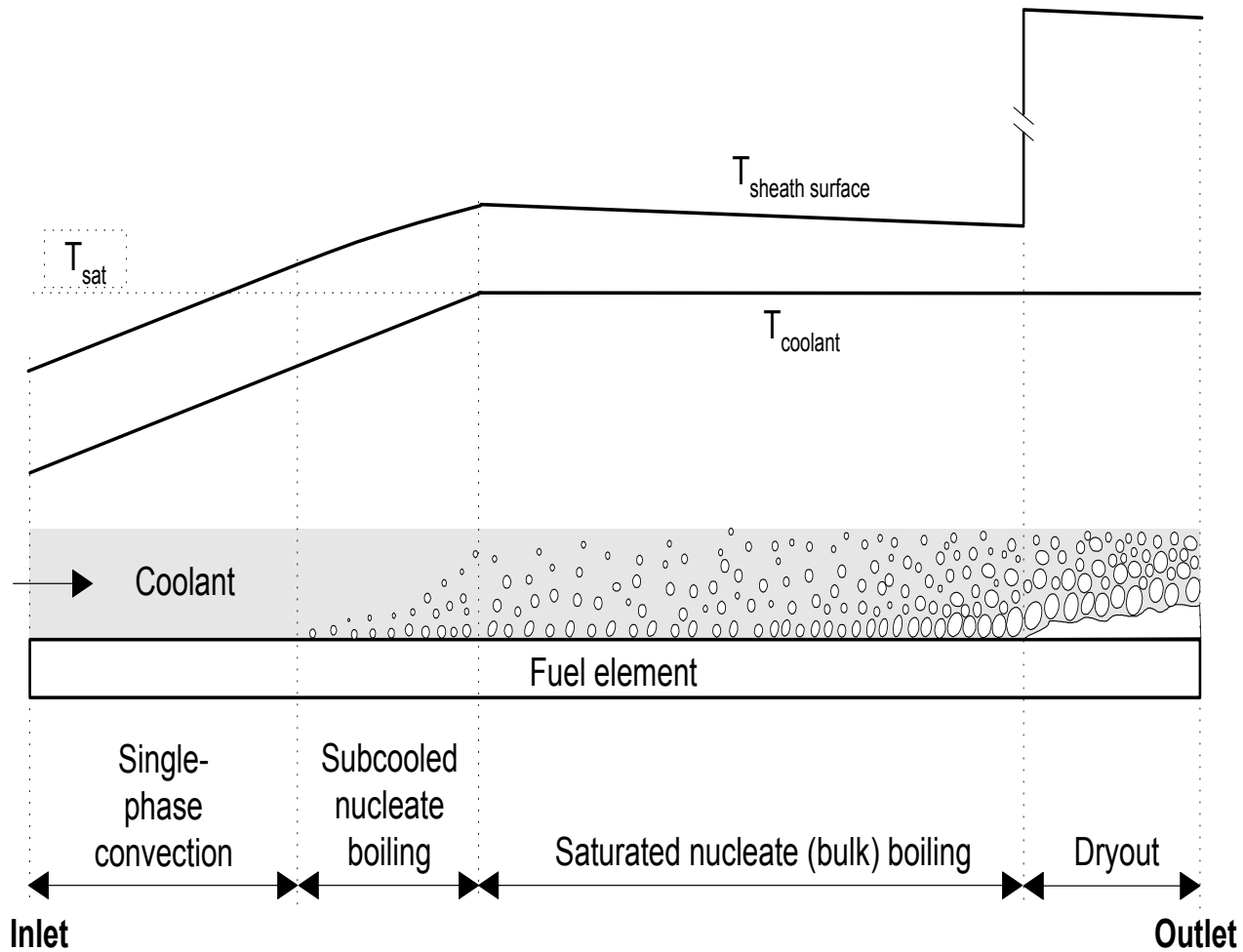



Factors Affecting CHF

- Coolant Sub-cooling
- Vapour Quality
- Coolant Velocity

Actual and Critical Heat Flux

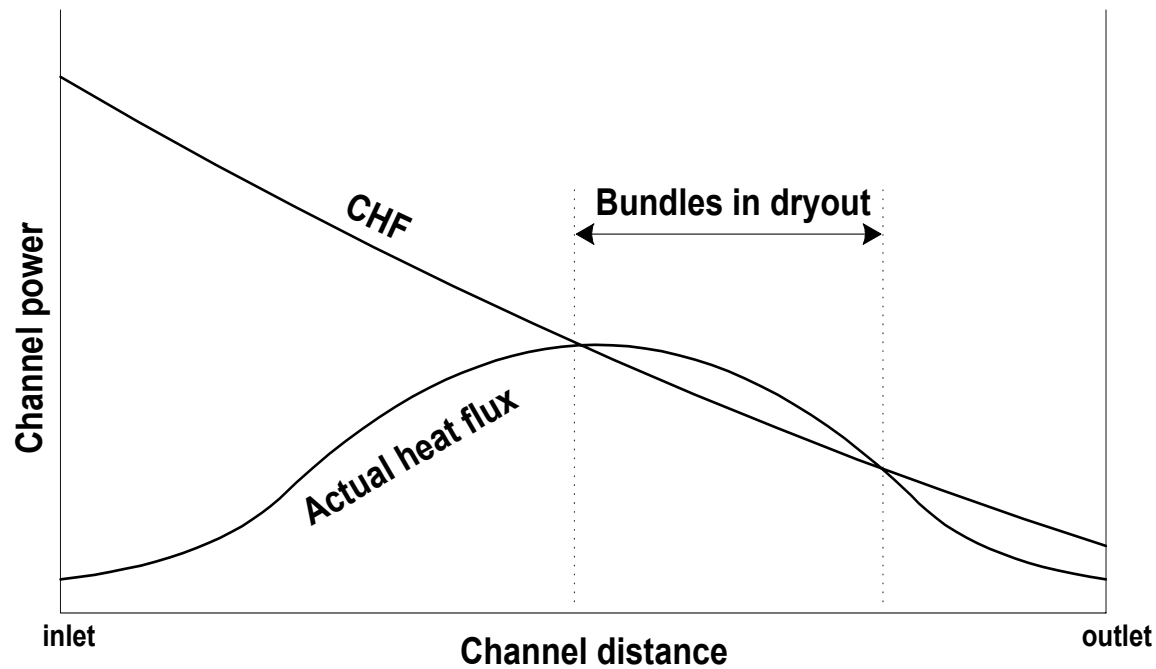



Critical Channel Power

- CCP
- The minimum channel power that gives dryout
- Varies with coolant conditions
- Varies with flux shape

Boiling and Flow

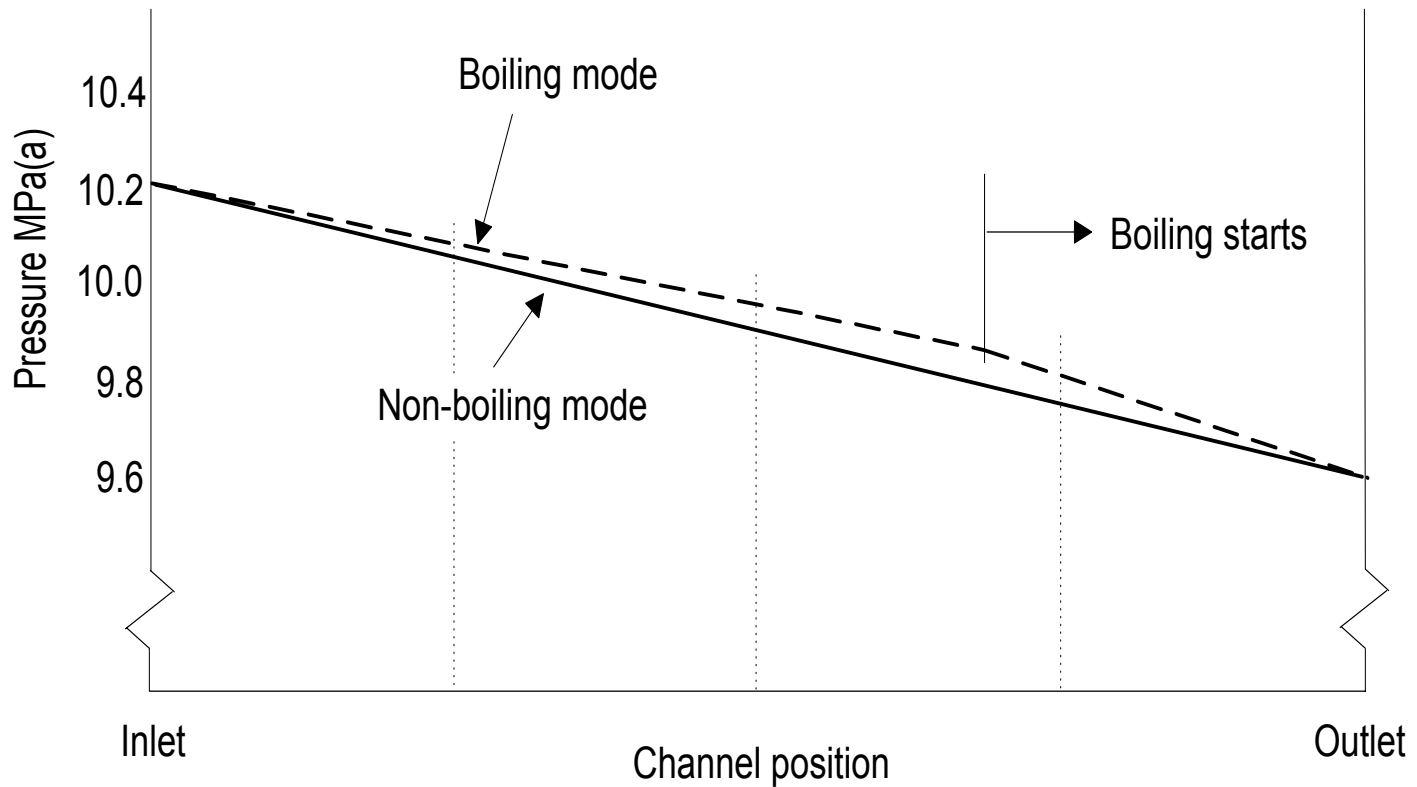

Temperature Profile

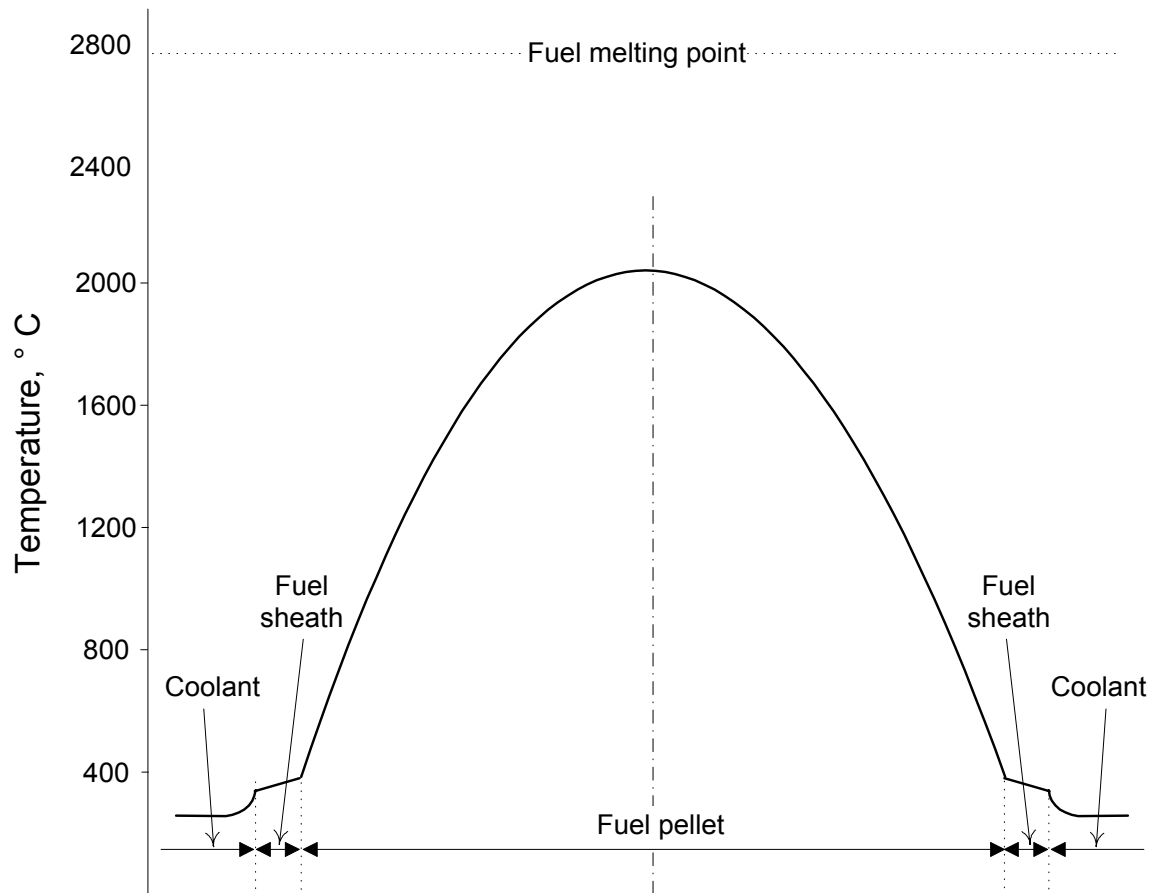

More Temperature Profiles

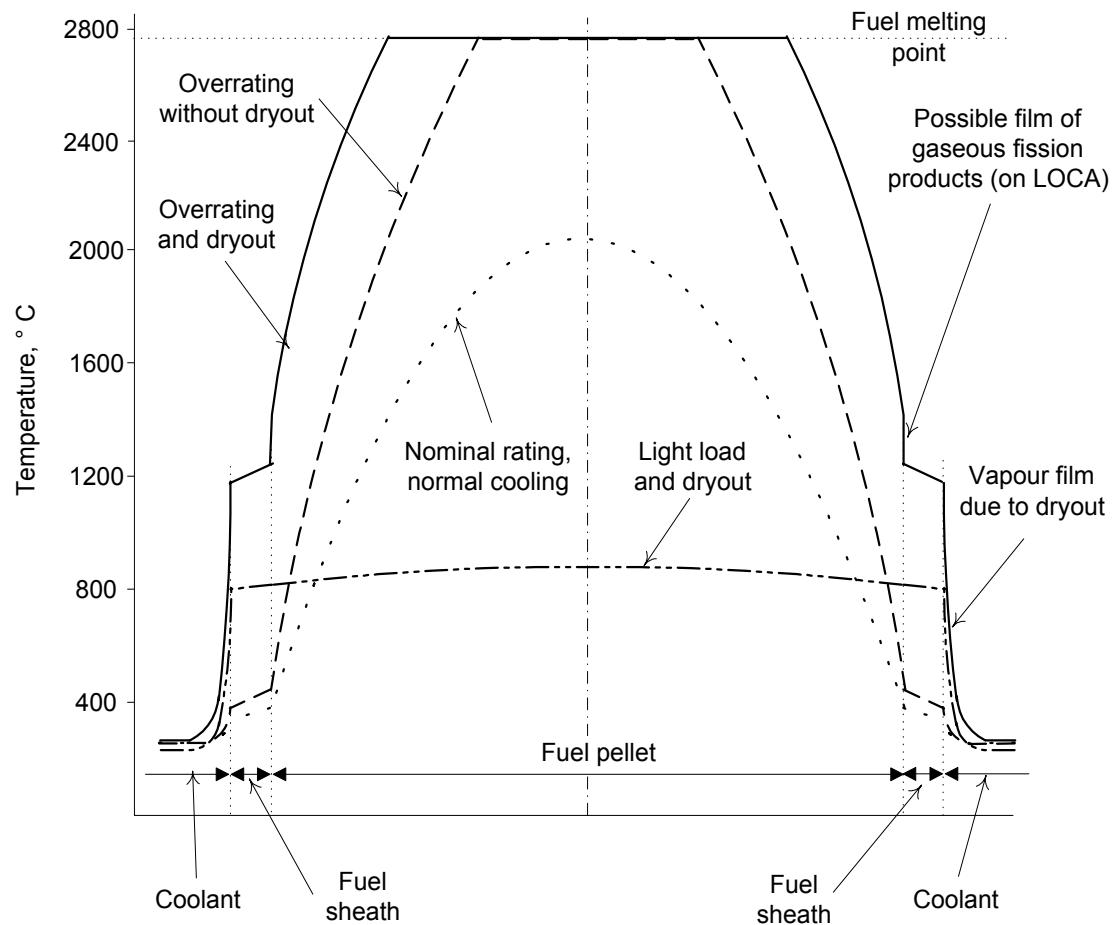

Bad things to do to fuel

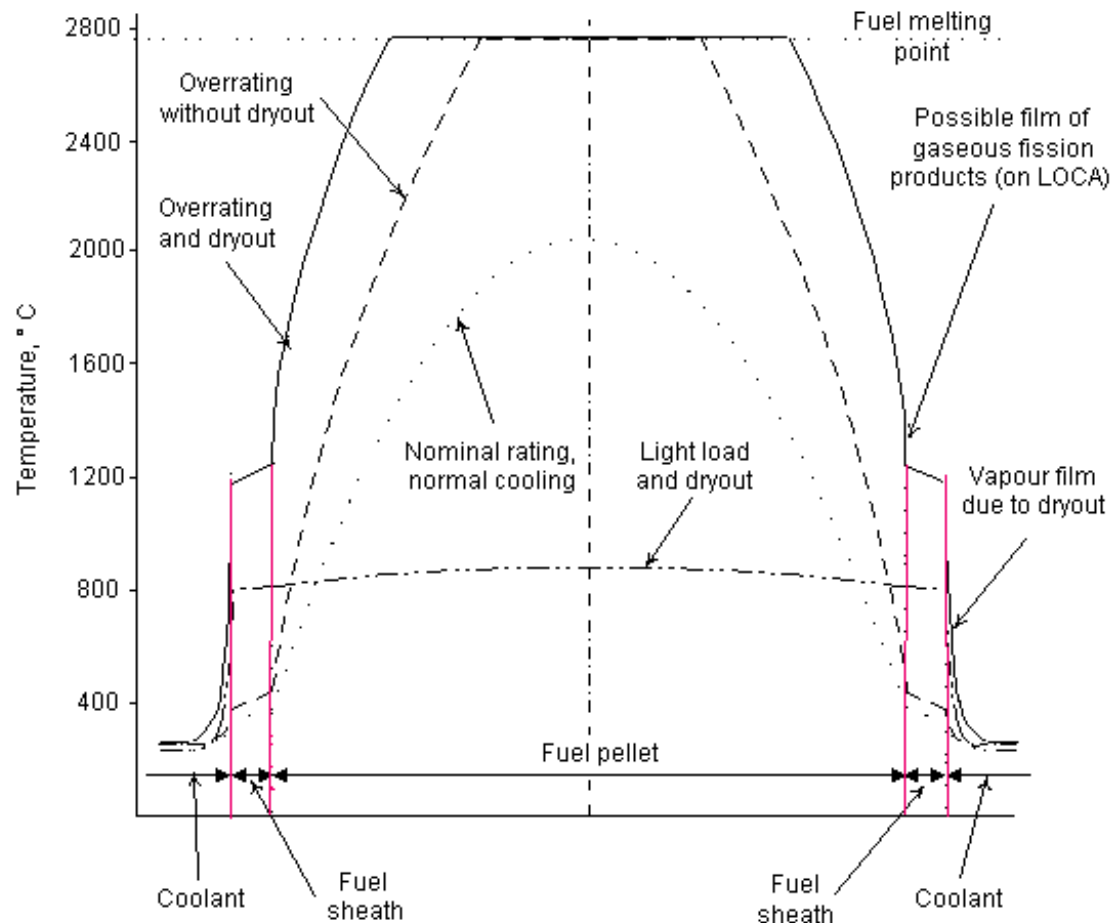

Low HTS Pressure

a) Temperature profile

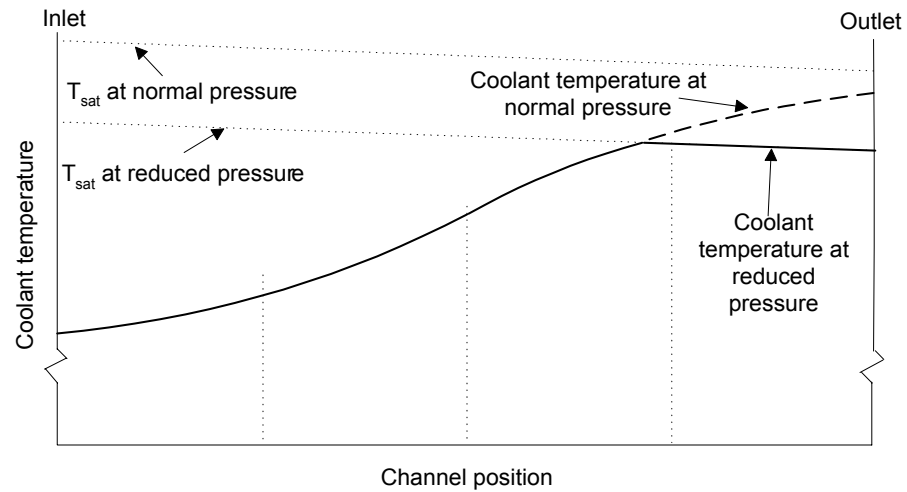

b) Heat flux profile

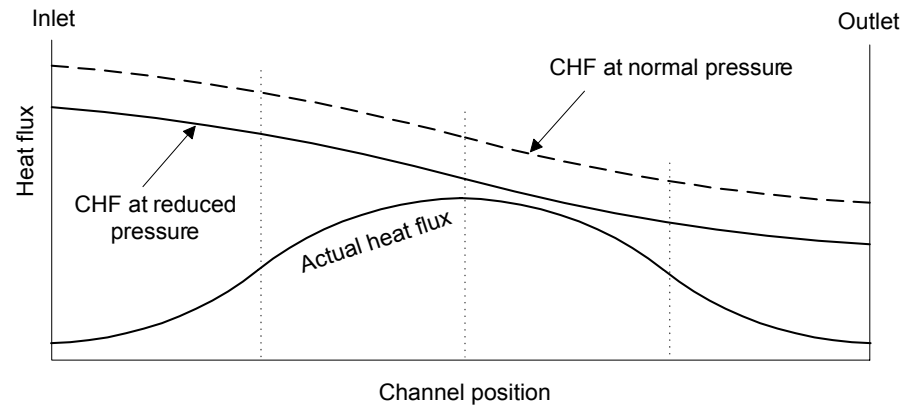

Reduced Flow

a) Temperature profile

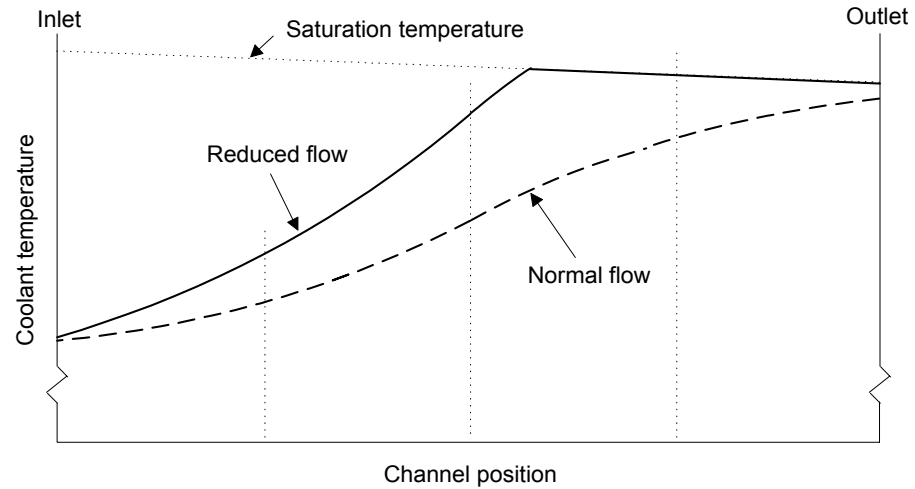

b) Heat flux profile

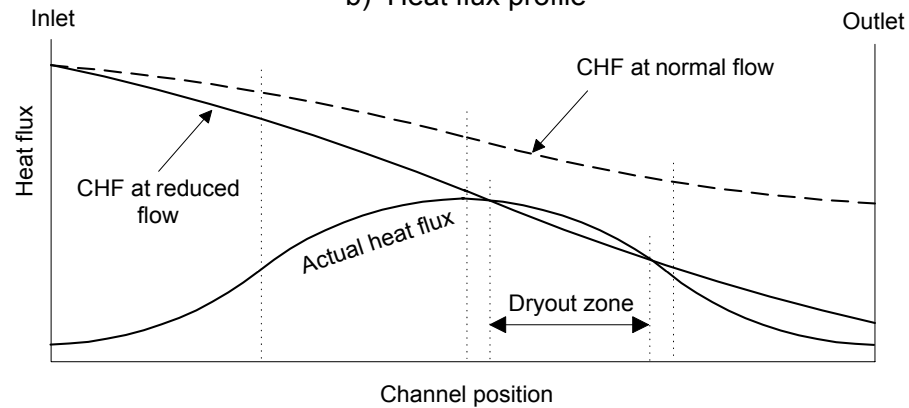

Inlet High Temperature

a) Temperature profile

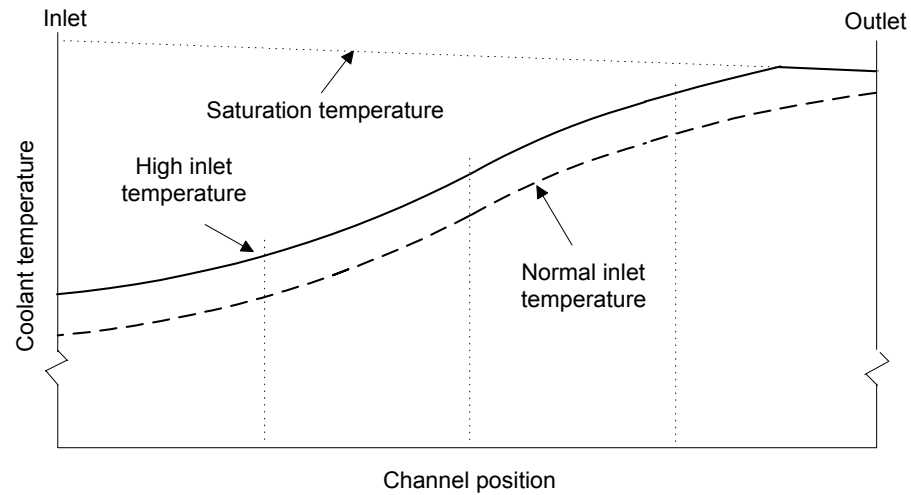

b) Heat flux profile

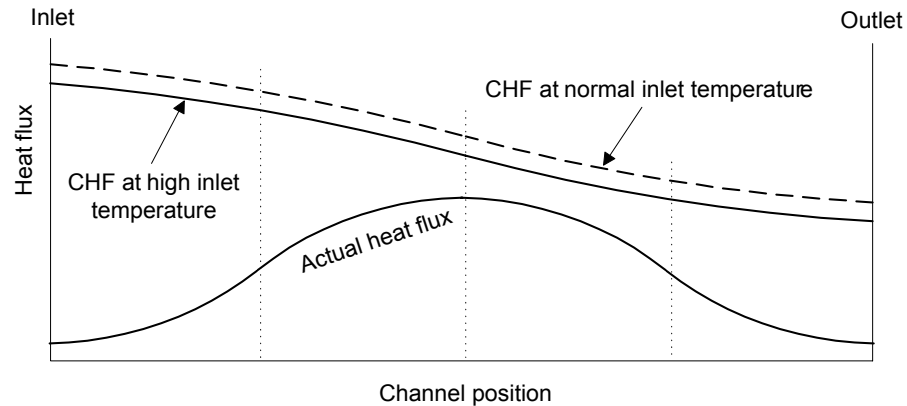

Flux Tilt to Outlet

a) Temperature profile

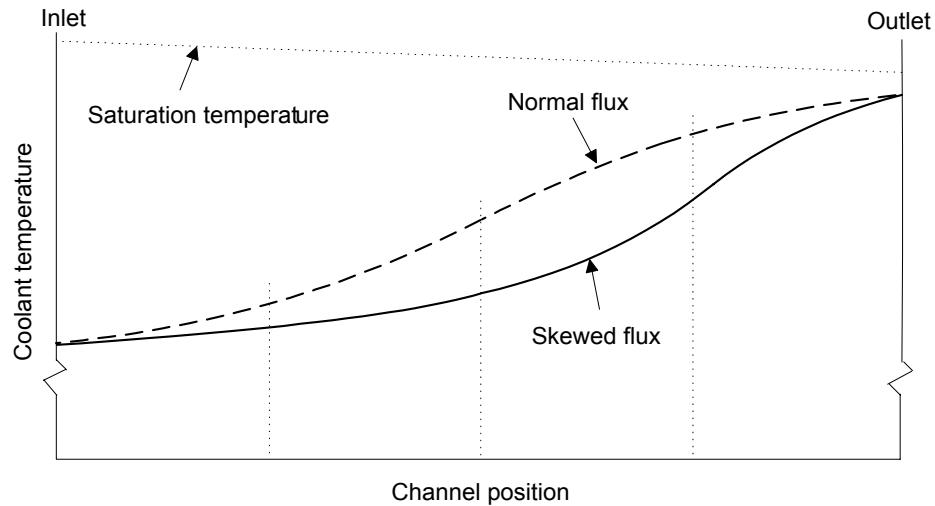

b) Heat flux profile

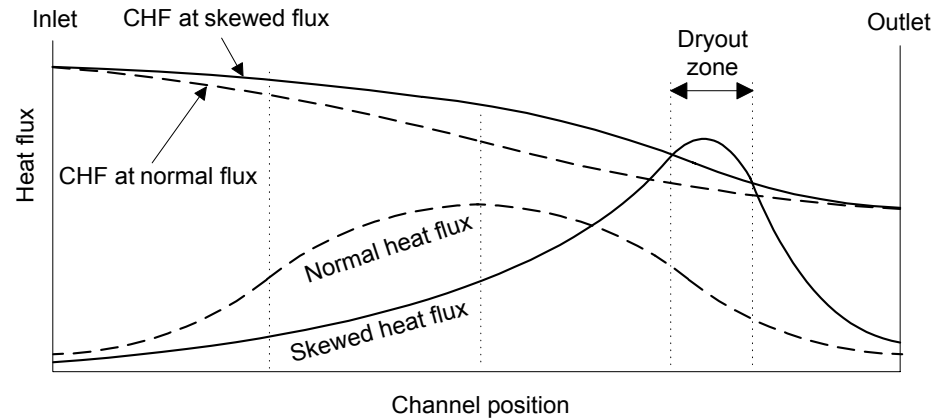

Flux Tilt to Inlet

a) Temperature profile

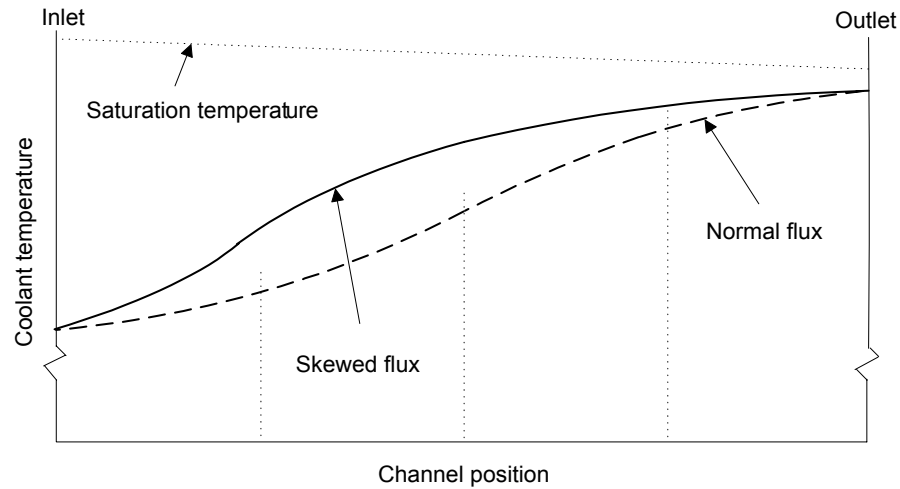

b) Heat flux profile

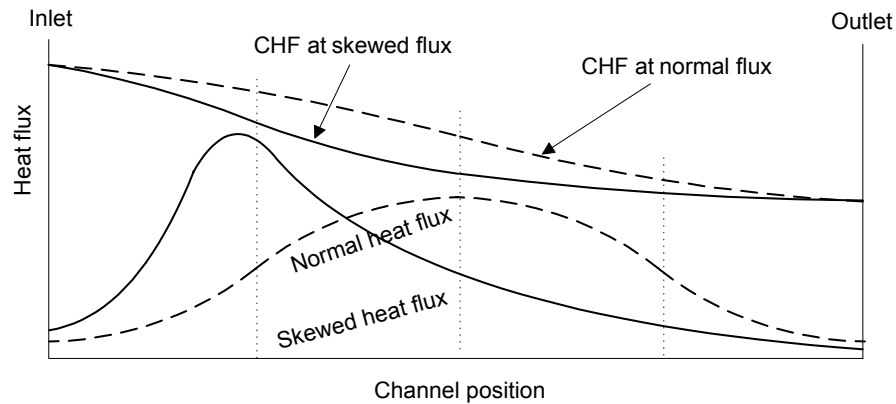

Excessive Channel Power

a) Temperature profile

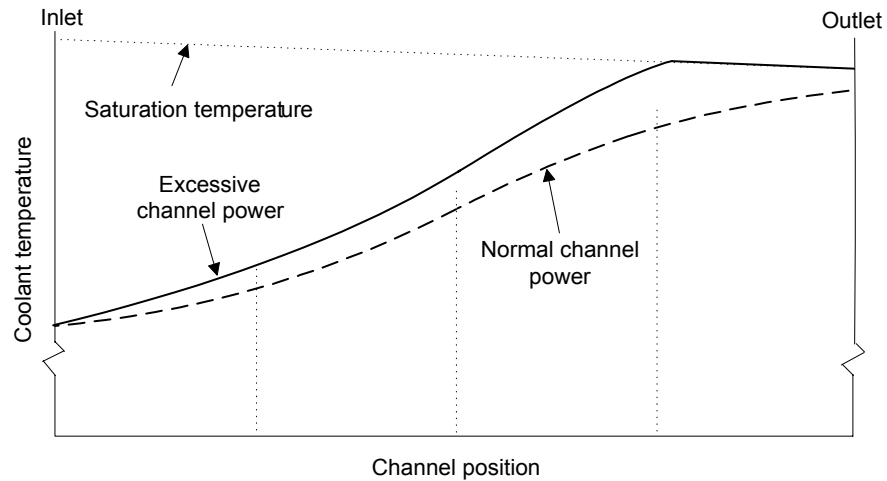

b) Heat flux profile

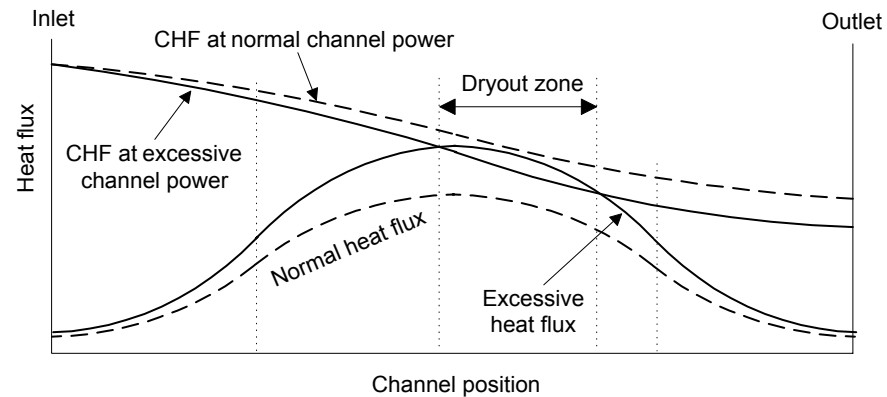



For You to do



Questions



HTS Components

HTS Feed & Bleed

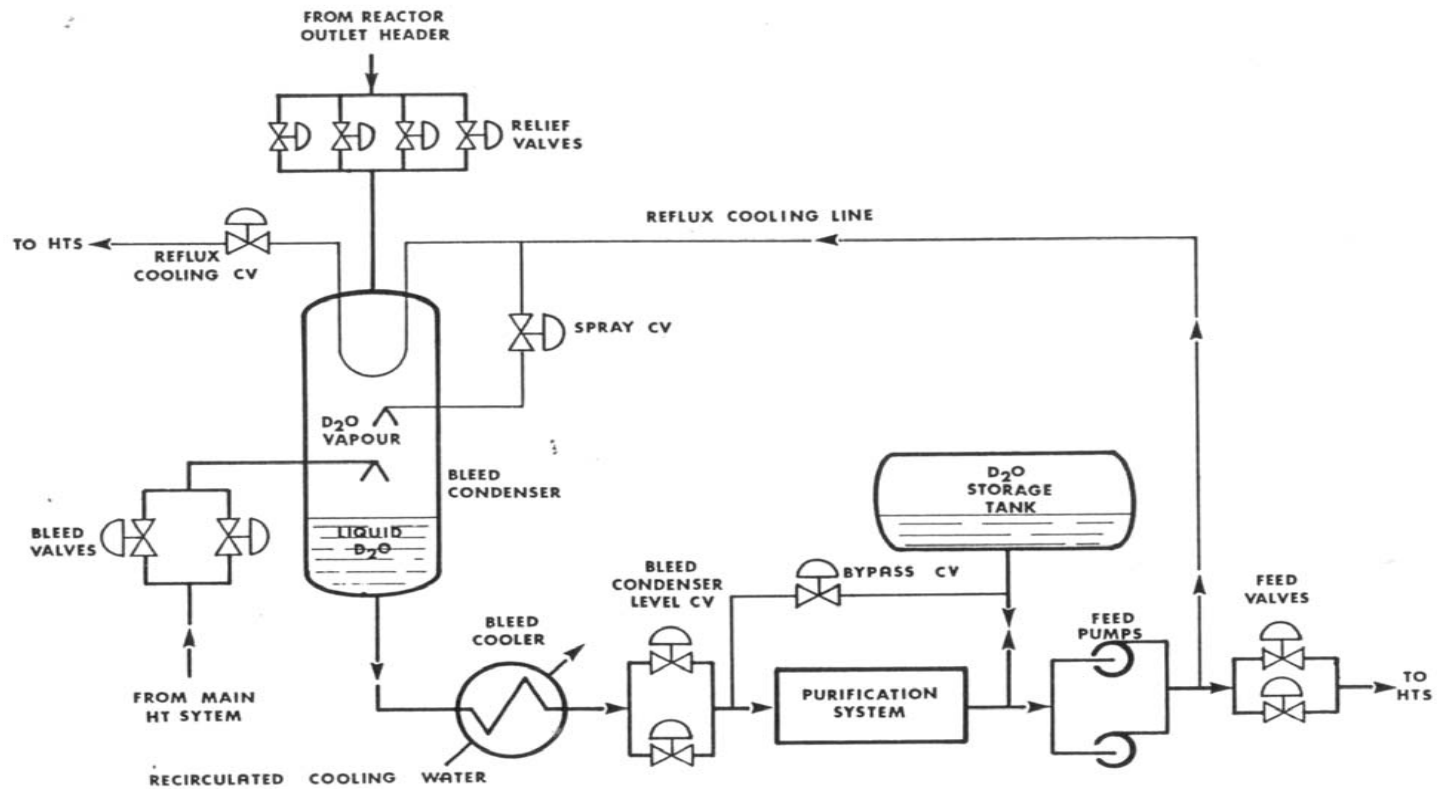

Bleed Condenser

- Non-condensable gases
 - Reduce heat transfer
 - Steam pressure rises
 - Increased reflux cooling
 - Vessel appears sub cooled
- Degassing Orifice

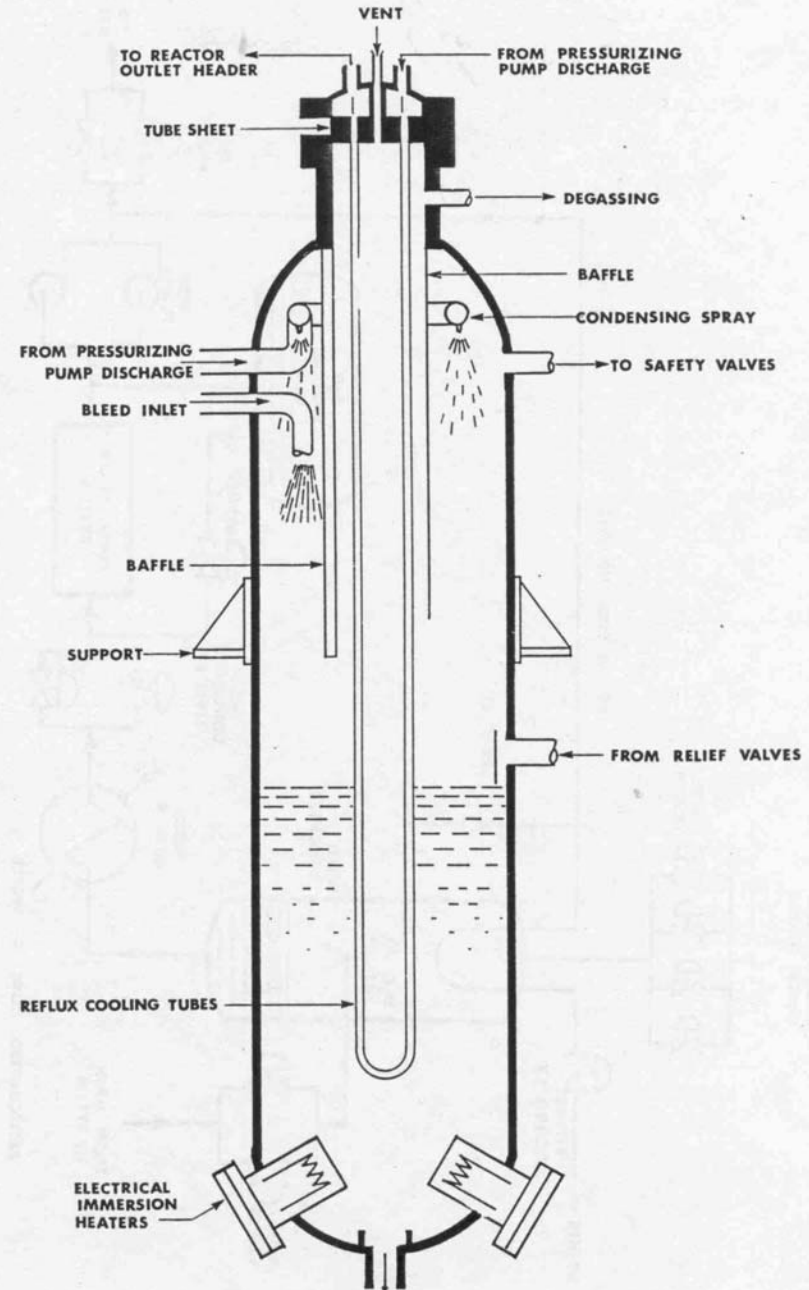

Pressurizer Control

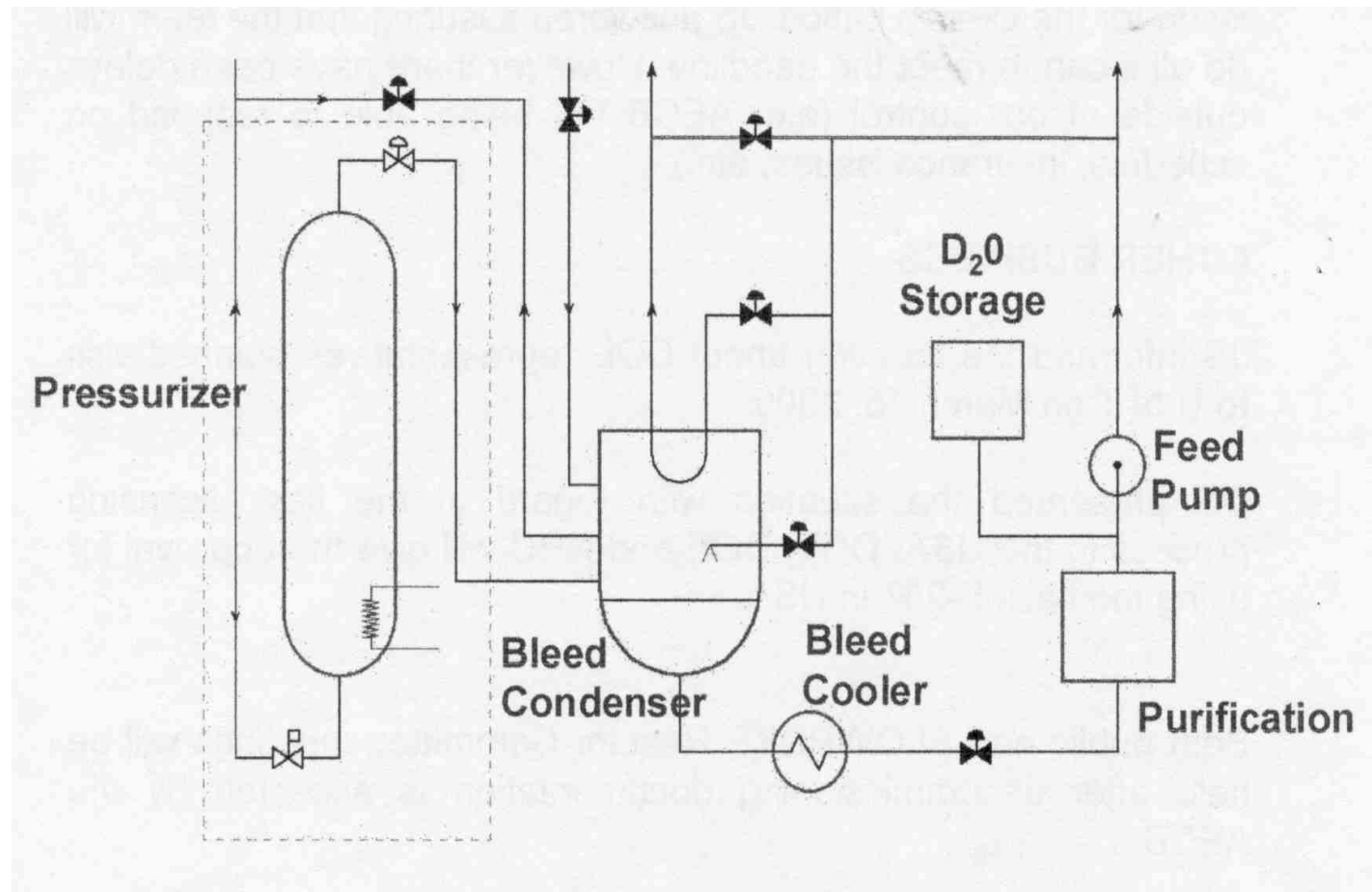



Boiler Shrink and Swell

- Boilers are probably more correctly called steam generators

Steady State Shrink and Swell

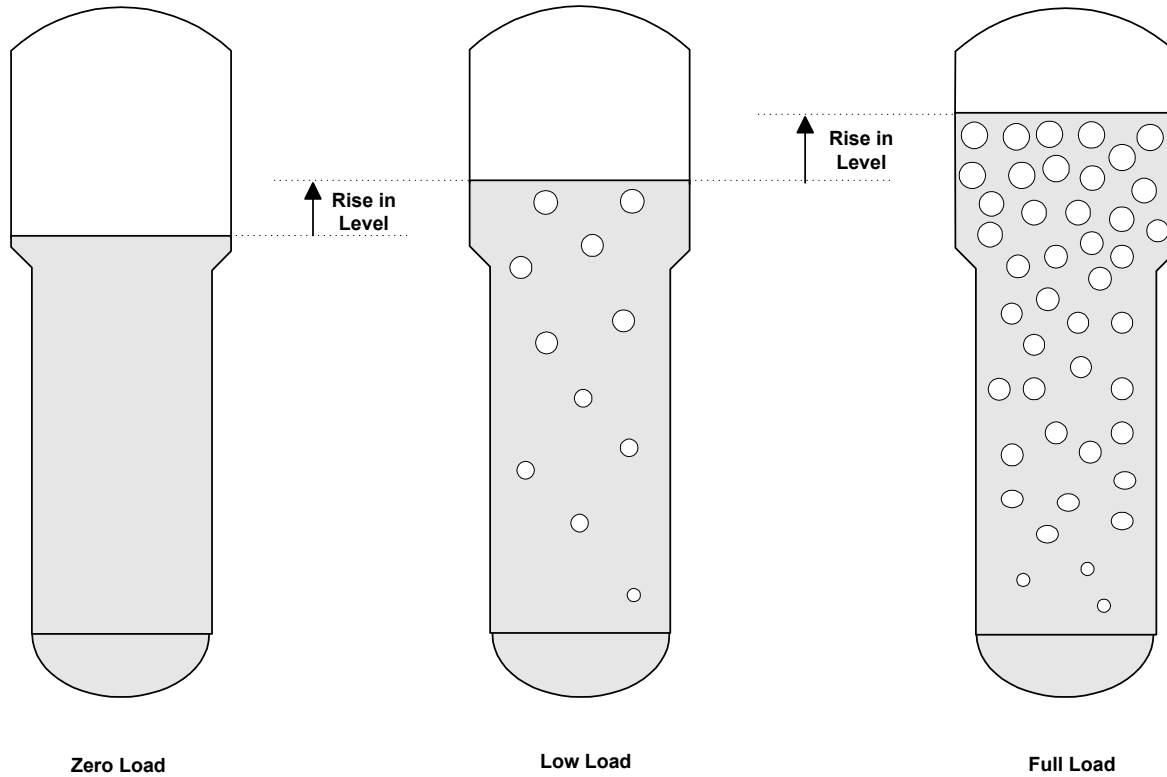



Transient Shrink and Swell

- Shrink and swell from short term effects
- Reactor power $\uparrow\uparrow$ boiler level $\uparrow\uparrow$
 - Boiling increases
- Boiler Pressure $\downarrow\downarrow$ boiler level $\uparrow\uparrow$
 - Water flashes to steam
 - Steam expands

Effects on the Downcomer

- Water flow into the annulus increases
- Water flow out of the annulus decreases
- Instrumentation sees a level increase

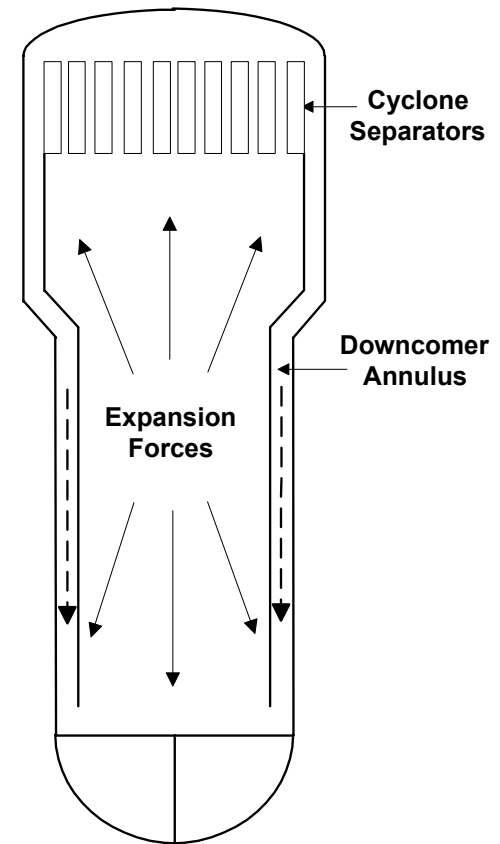

Boiler Level Control

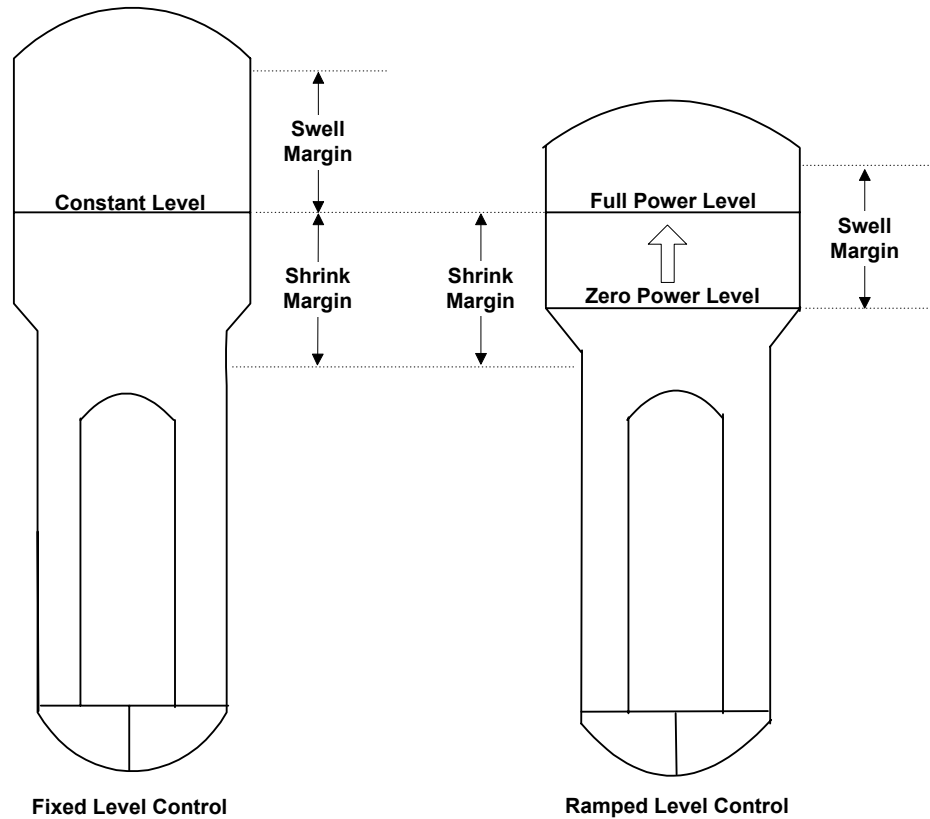



Improper Level

- Low

- If tubes are uncovered

- Reduce heat transfer
- Time in loss of feedwater events is reduced
- Reactor power automatically reduced
 - Setback or stepback and finally a trip

- High

- High vapor content in steam
- Slugs of water to turbine
- Turbine trip



Boiler Pressure

- Boiler pressure is the key parameter in matching heat source to sink
- Reactor Leading
- Reactor Lagging

The key to plant control



Warm-up and Cool-down

- Heat transfer in the boiler

$$\dot{Q} = U \cdot A \cdot \Delta T_m$$

- At low power levels the HTS is about the same temperature as the boiler



R_x for Warm-up

- Put some energy into HTS from pumps and reactor power
- Increase boiler pressure
- Boiler temperature follows (saturated vessel)
- HTS temperature follows that



R_x for Cool-down

- Heat sources are pumps and decay heat
- Boiler pressure is ramped down
- Steam energy released is greater than energy input
- Down go temperatures
- Limit around 130-150°C due to huge volume of steam required



Ideal Temperature Ramps

- 2.8°C a minute
- This rate minimizes
 - Thermal stress
 - Probability of delayed hydride cracking
 - Feedwater loss



For You to do

Questions

